



ALUES

DIVISIÓN INTERIORES
ΩMEGA



SOLUCIÓN INDUSTRIAL



SOLUCIÓN AJUNQUILLADA

CARACTERÍSTICAS TÉCNICAS

- ! Perfilera para separar espacios interiores, permitiendo el paso de luz y creando sensación de amplitud.
- ! Soluciones con perfiles de aluminio de pequeñas dimensiones para conseguir una visión panorámica y una perfecta entrada de luz.
- ! Diferentes posibilidades de diseño en función de si desea un estilo más clásico incorporando el modelo con junquillo o un estilo más industrial.
- ! Sistemas de división de interiores.
- ! Sección 40 mm.
- ! Acristalamiento de 5 y 6 mm.
- ! Aperturas:
 - Fijo
 - Abatible 1 y 2 hojas.
 - Corredera 1 y 2 hojas
 - Replegables:
 - Hojas pares, 2-0, 4-0 y 6-0.
 - Hojas impares, 3-0, 5-0 y 7-0.
 - Doble apertura, 2+2, 3+1 y 3+2.



DETALLE 2D

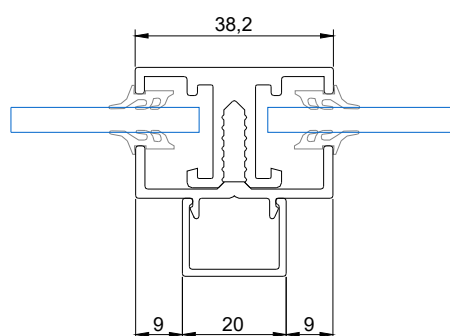

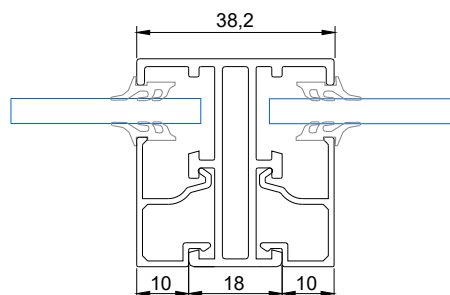

Solución industrial

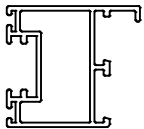
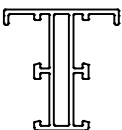

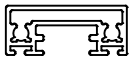
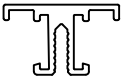
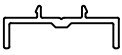
Solución ajunquillada

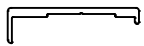

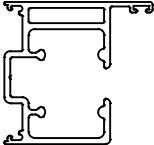
Referencia	Dibujo	Descripción	Momento de Inercia cm ⁴		Perímetro dm ²
			lx	ly	
7600		"U" pilastra industrial	0,2	0,4	9,7
7607		Hoja 40 mm	6,6	4,8	40,0
7608		Pilastra junquillo	4,9	1,5	31,5
7609		Junquillo 25 mm	0,2	0,3	11,8
7610		Marco 40 mm	0,6	4,4	29,3
7620		Pilastra industrial	1,4	1,6	20,0
7621		Perfil interior industrial	0,1	1,8	12,7

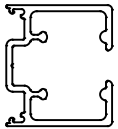
Referencia	Dibujo	Descripción	Momento de Inercia cm ⁴		Perímetro dm ²
			lx	ly	
7622		Tapeta hoja centro	0,1	2,5	11,4
472		Perfil batiente	0,2	0,2	10,4
481		Guía superior con ala	12,3	7,3	42,9
487		Guí inferior encastrada	14,3	1,0	14,3
489		Guía superior sin ala	7,0	4,8	31,6

481 Guía superior con ala

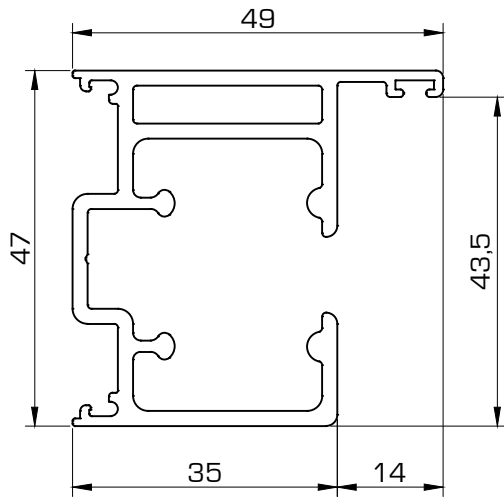

489 Guía superior sin ala

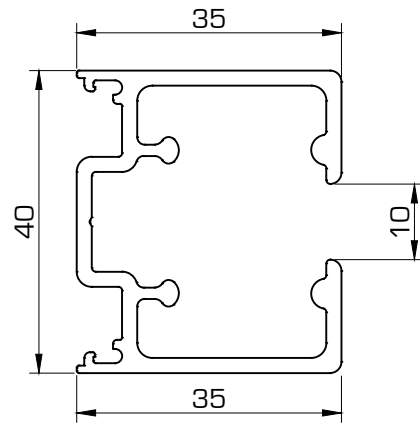

7610 Marco 40 mm

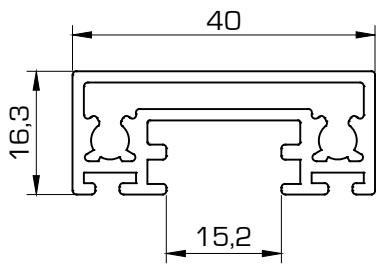

487 Guía inferior encastrada

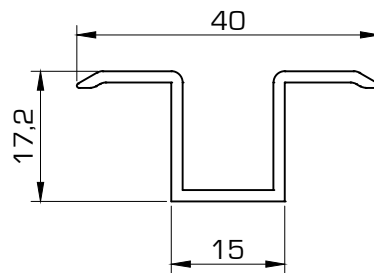

7622 Tapeta hoja centro

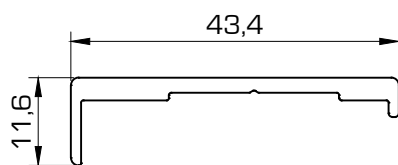

472 Perfil batiente

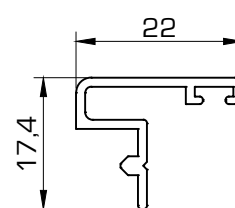

7607 Hoja 40 mm

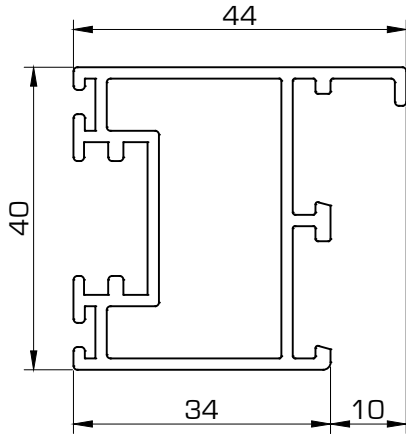

7621 Perfil interior industrial

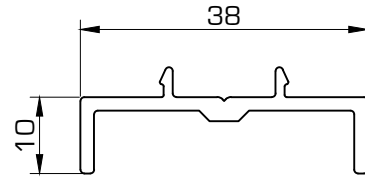

7620 Pilastra industrial

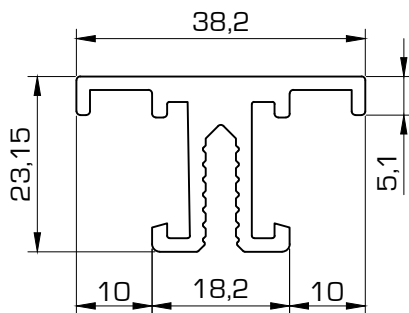

7600 "U" Pilastra industrial

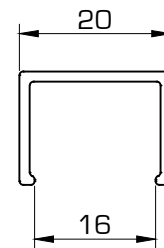



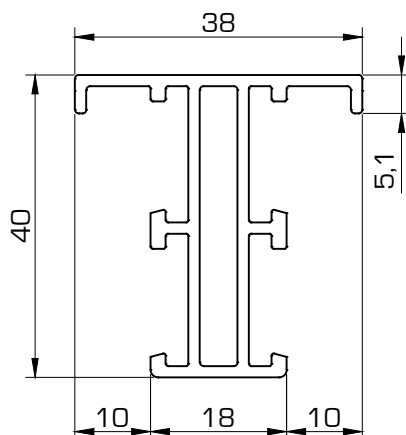



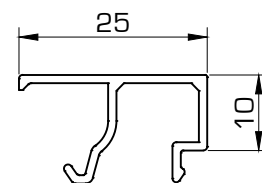

7608 Pilastra junquillo



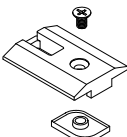

7609 Junquillo 25 mm

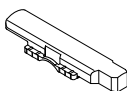
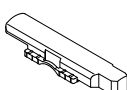
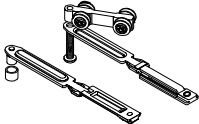

Referencia	Dibujo	Descripción	Observaciones
E061		Escuadra 37 x 16	
E068		Escuadra alineación interior	
E202		Escuadra alineación exterior	
C105		Cerradura con llave y gancho	
C106		Rodillo cerradura con picaporte	
C107		Picaporte cerradura con picaporte	
C108		Cerradero (C106 , C107)	
F020		Cepillo 7 x 12	
G010		Junta replegable	
G056		Junta interior	

Referencia	Dibujo	Descripción	Observaciones
J030		Tope final de carrera	
P028		Pletina bloqueo final carrera	
P029		Patín guiado extramuros	
R033		Patín sobrepuesto suelo	
C307		Cremona apertura exterior	
C046		Cerradero 2027	
C308		Manilla plana	
P026		Pasador doble acción	
J038		Juego tornillo accionador	

Referencia	Dibujo	Descripción	Observaciones
P027		Pomo tirador 215	
P021		Terminal falleba sup./inf. de 9 mm	
P022		Terminal falleba sup./inf. de 11 mm	
P025		Terminal falleba sup./inf. de 14 mm	
B094		Bisagra individual	
R074		Bisagra tandem [juego sup / inf.]	
R075		Rodamiento conjunto hojas pares	
R086		Rodamiento carrera extramuro	
R087		Rodamiento corredera intramuros	

ABATIBLE 1 HOJA



ABATIBLE 2 HOJAS

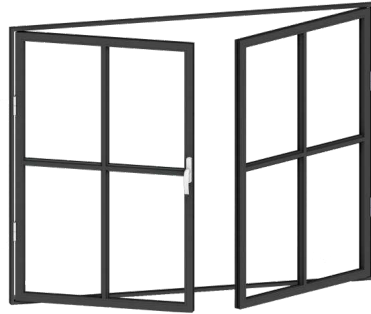

ABATIBLE 1 HOJA + FIJO



CORREDERA 2 HOJAS

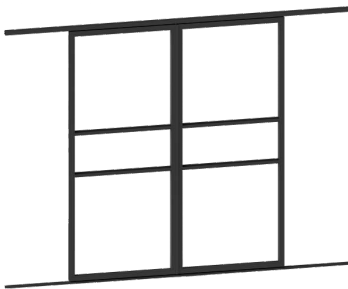

CORREDERA + FIJO



REPLEGABLE HOJAS PARES
2+0 | 4+0 | 6+0



REPLEGABLE HOJAS IMPARES
3+0 | 5+0 | 7+0



REPLEGABLE DOBLE
APERTURA 2+2 | 3+1 | 3+2

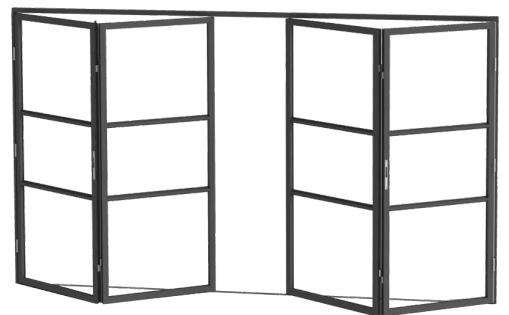

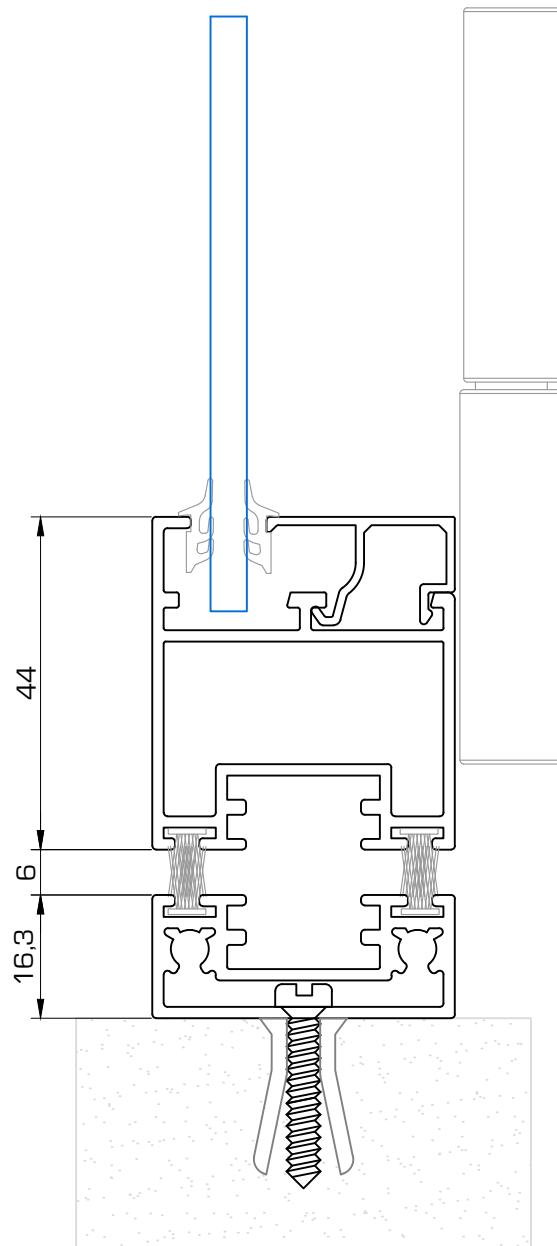
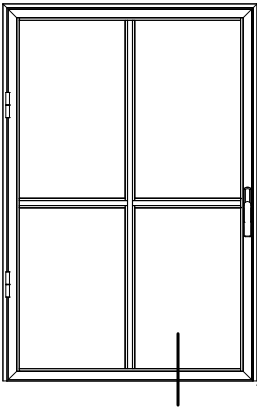

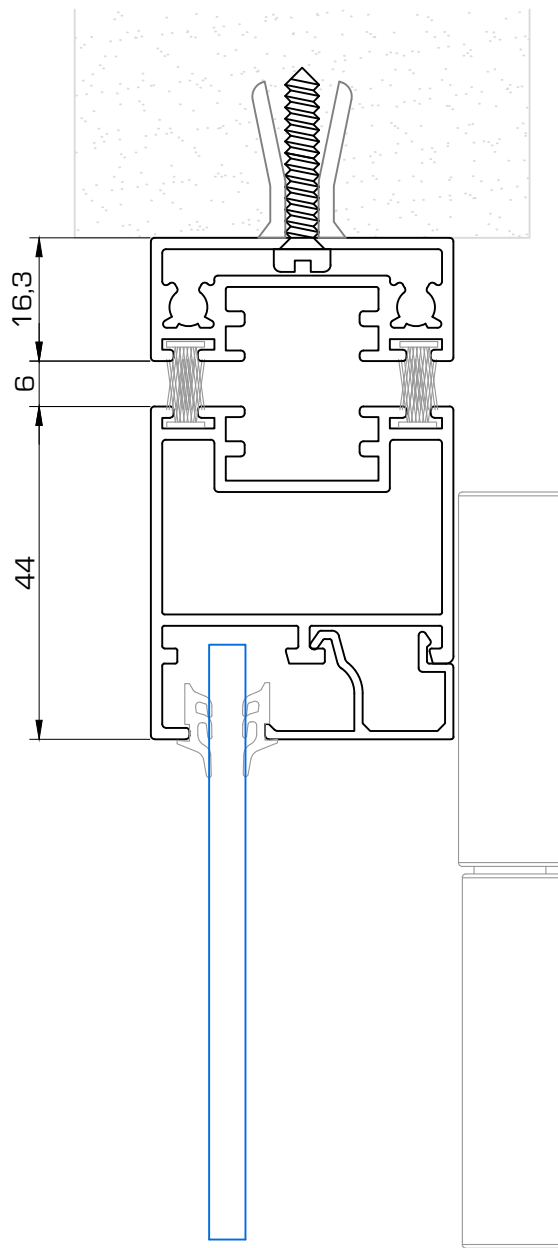
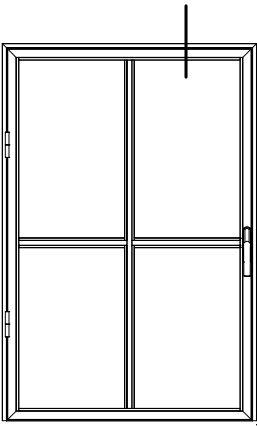

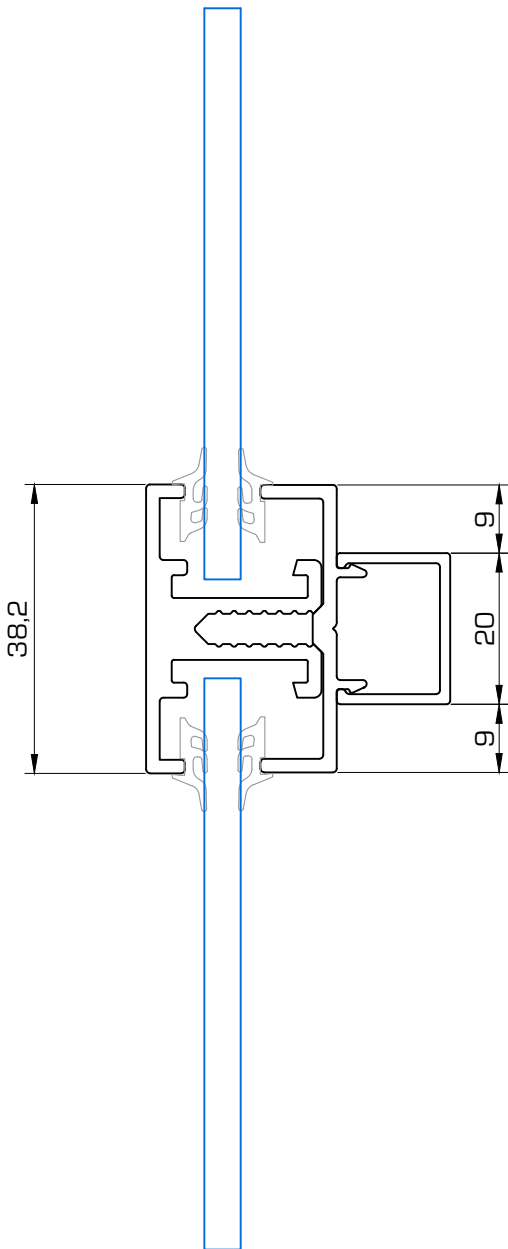
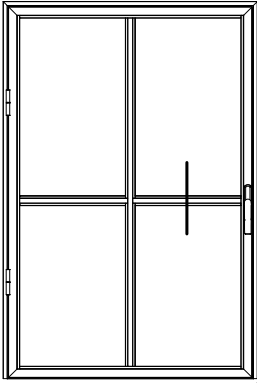

Detalle con junquillo

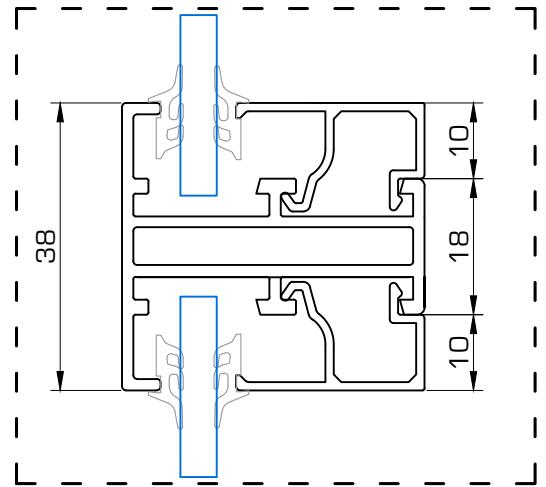

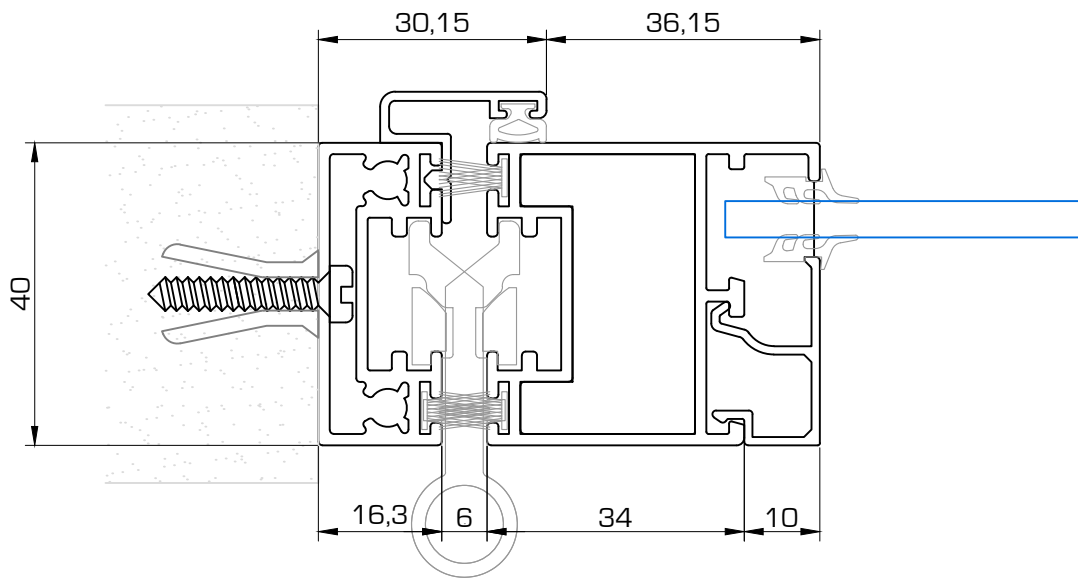
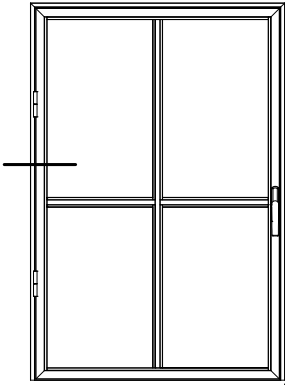

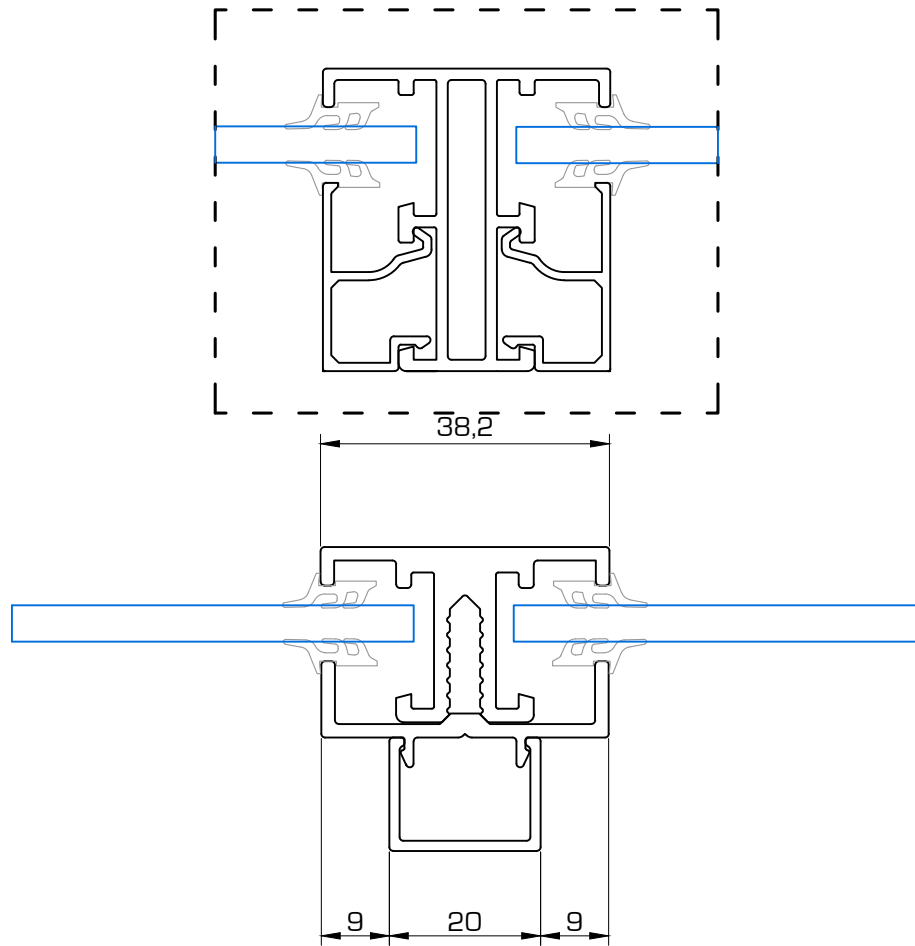
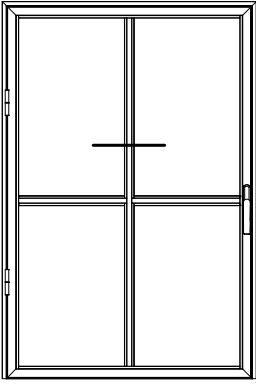

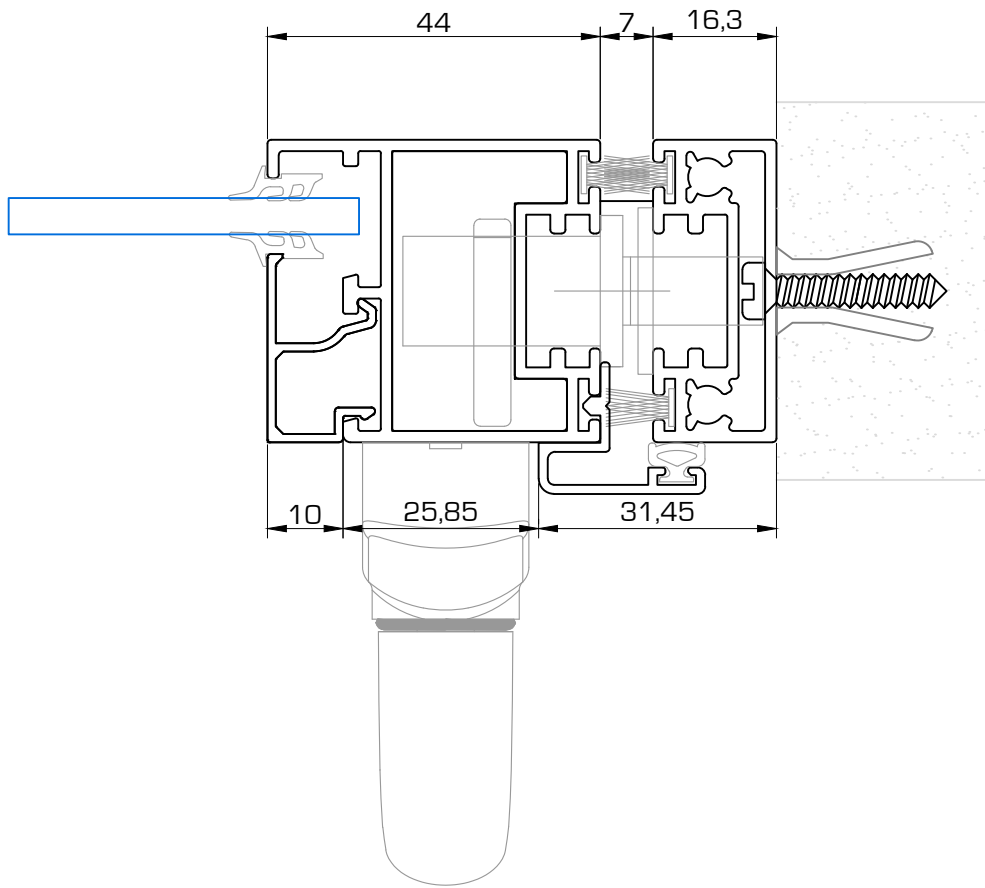
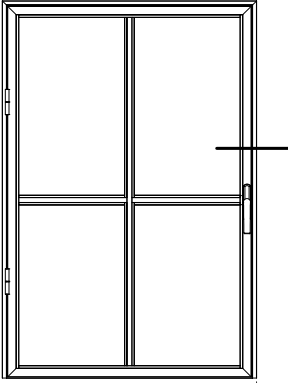

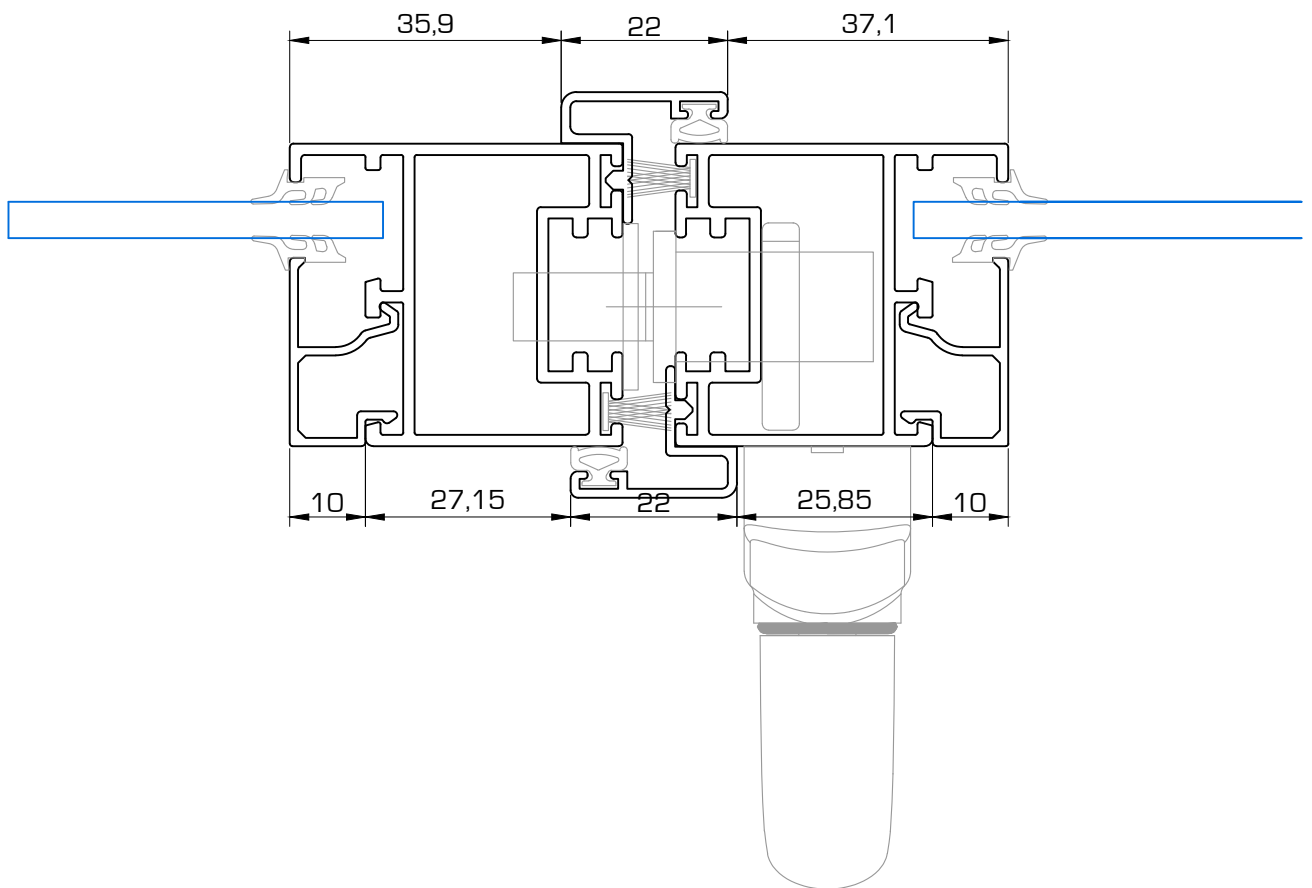
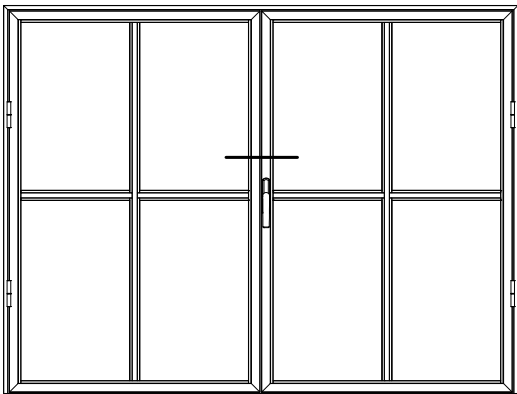

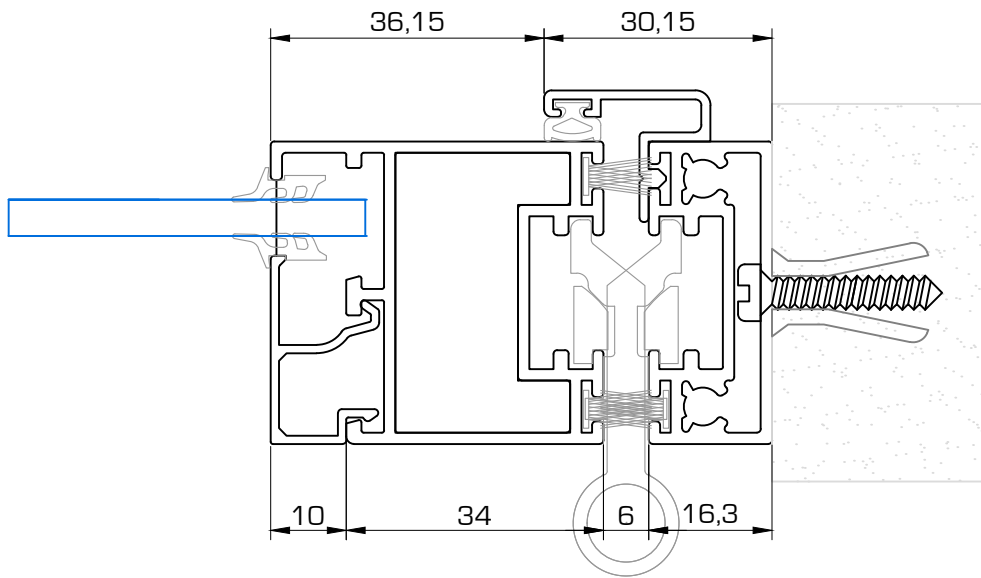
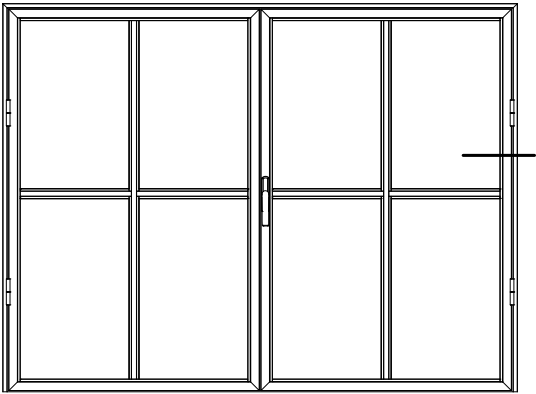

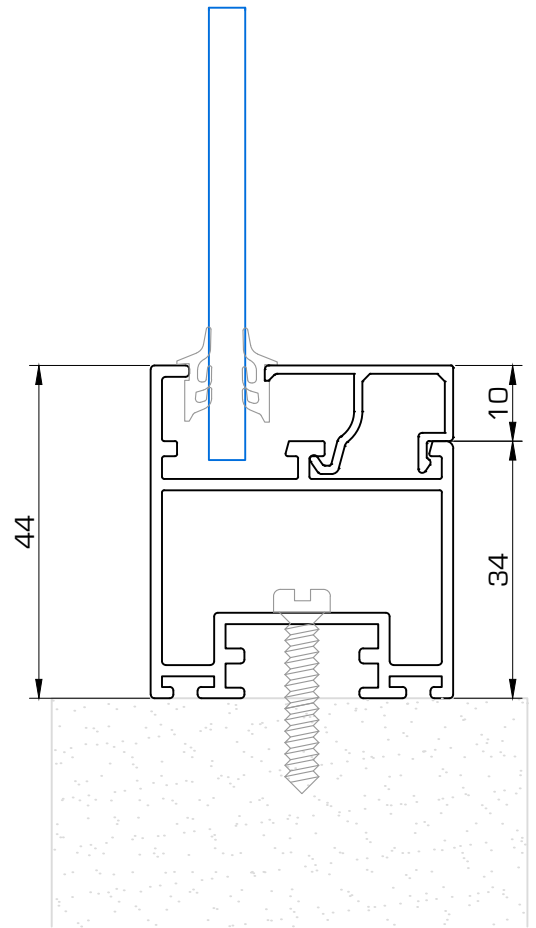
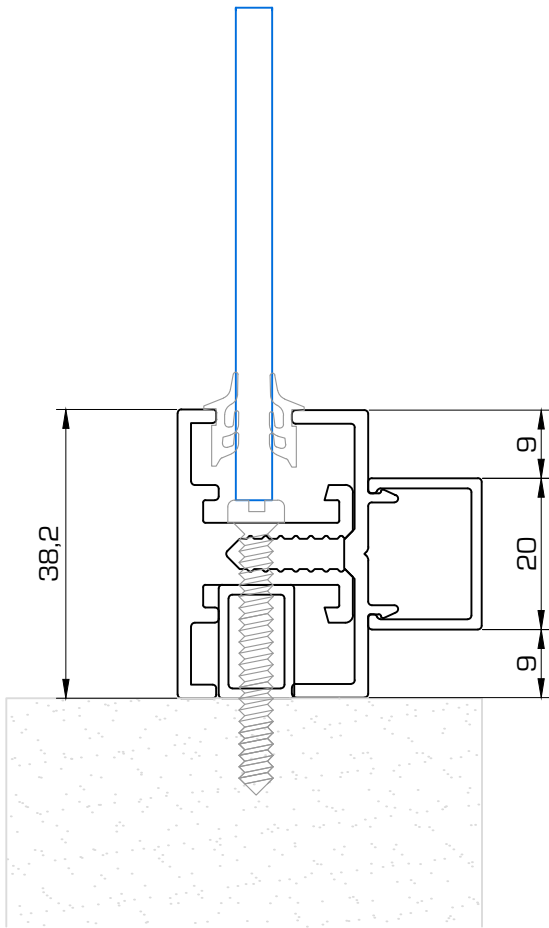
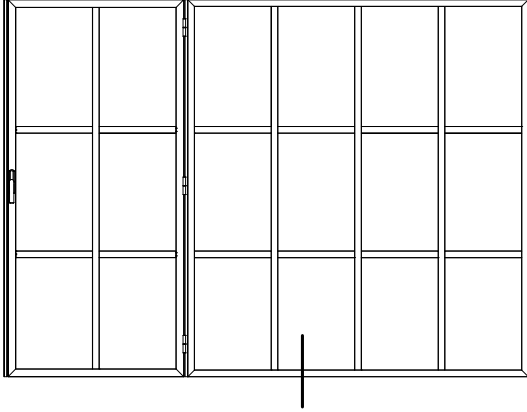

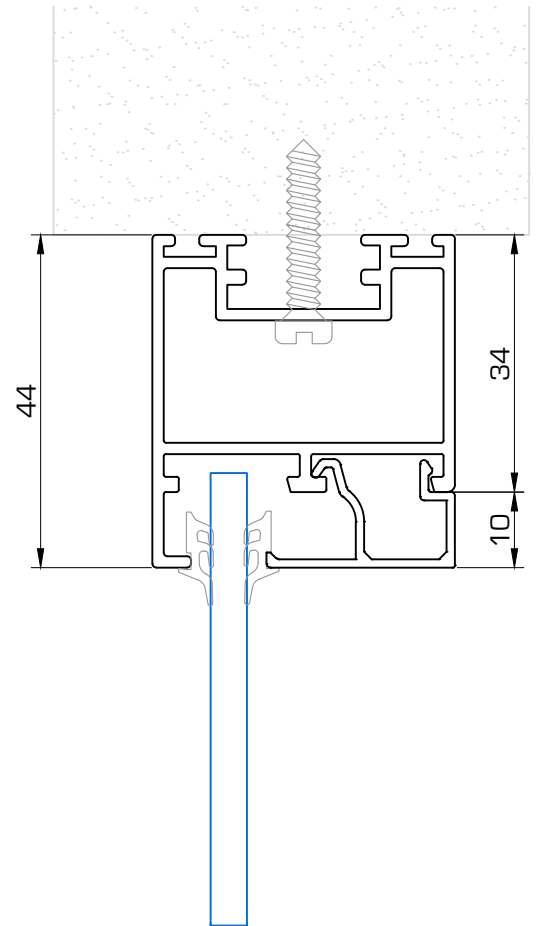
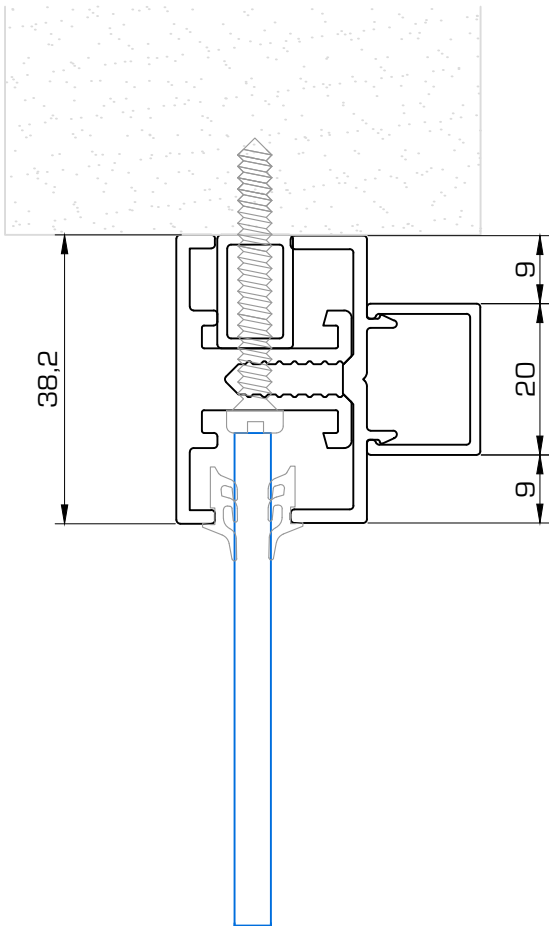
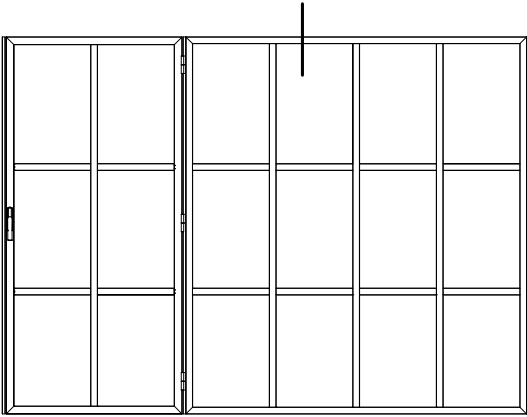

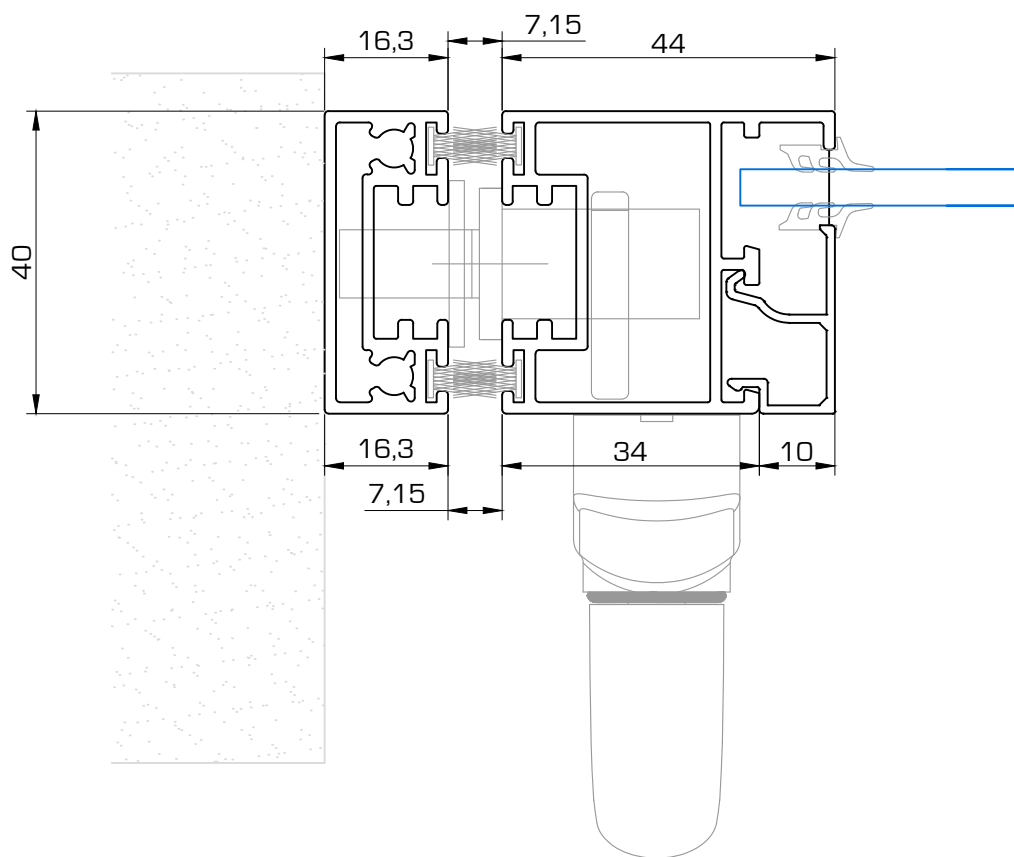
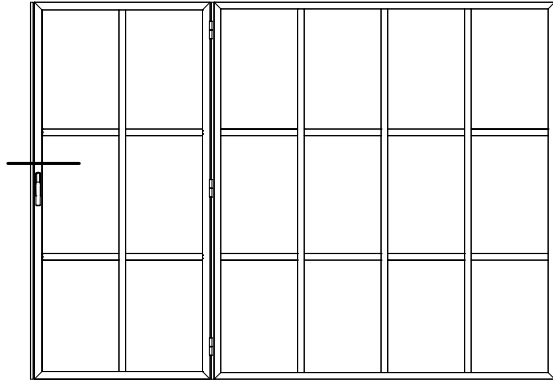

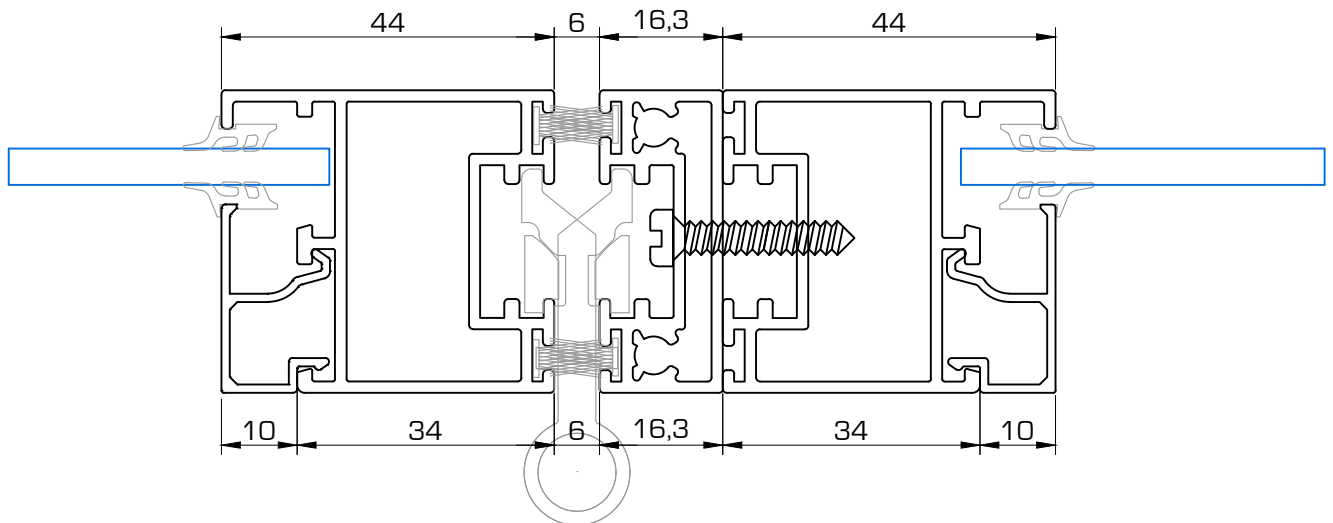
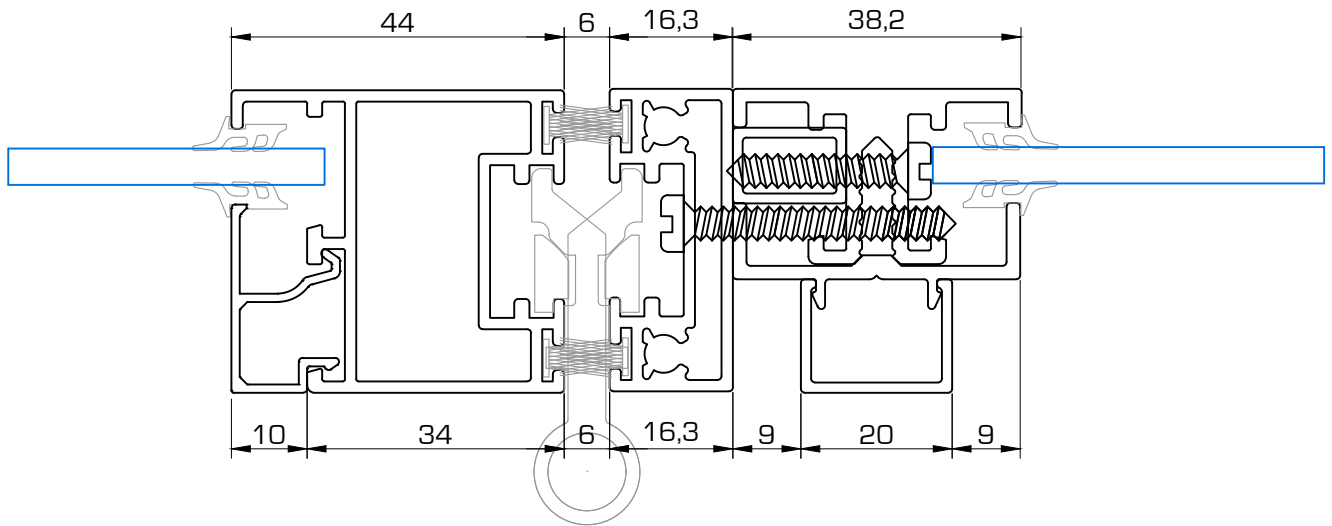
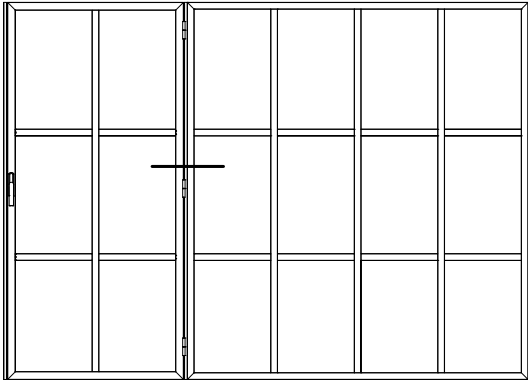

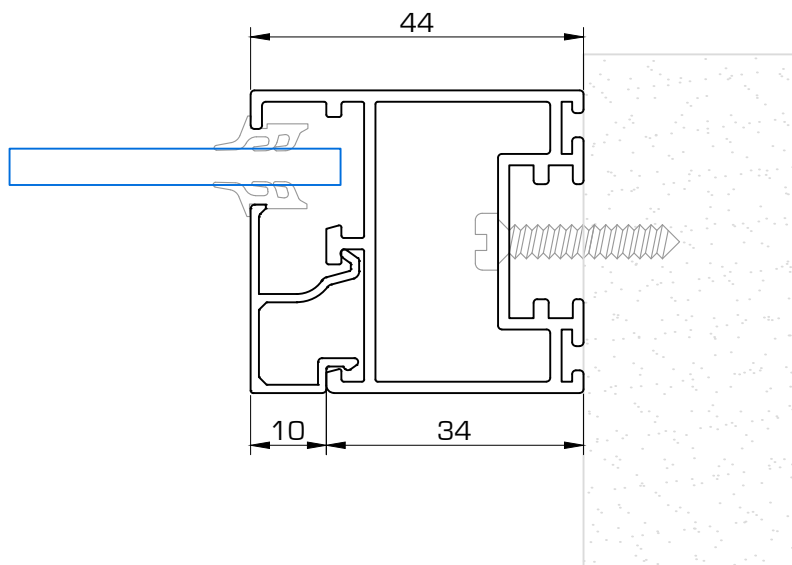
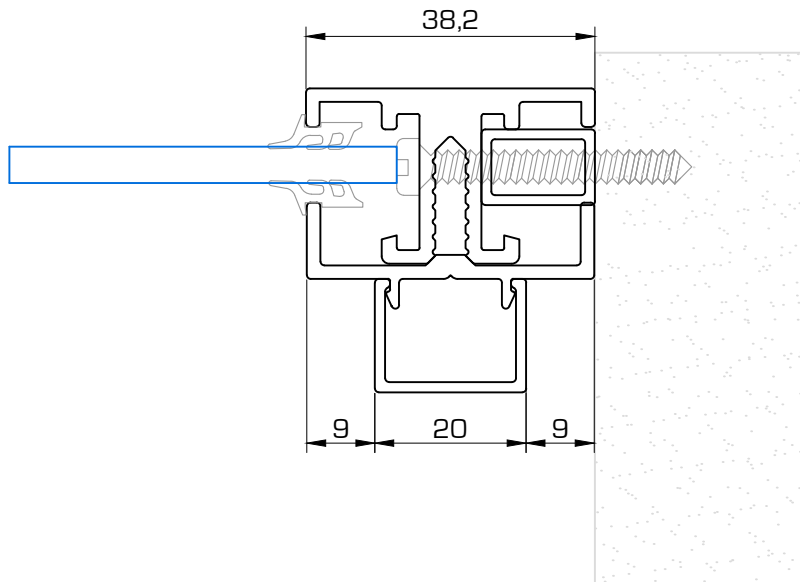
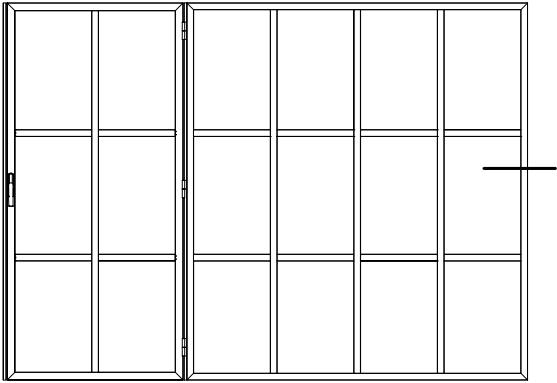

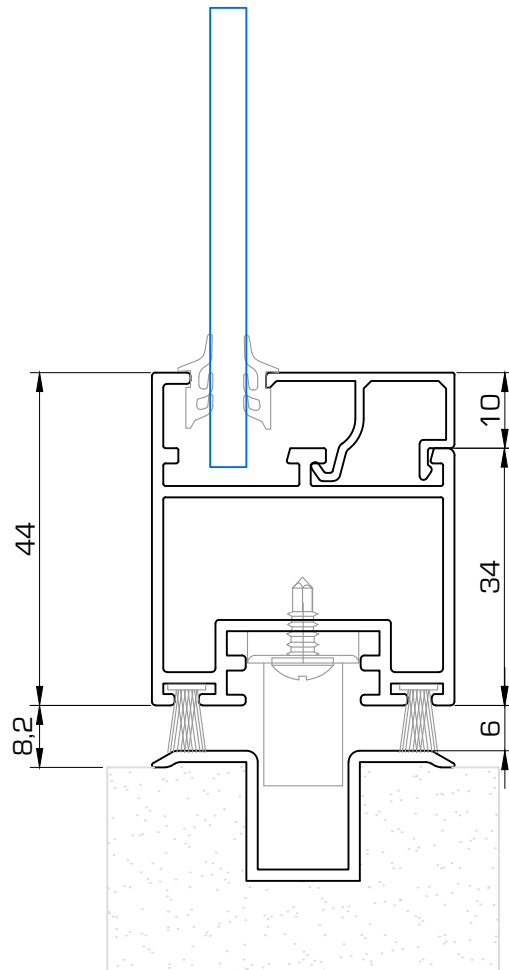
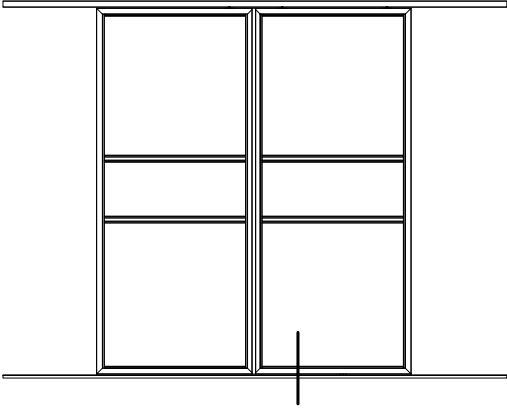

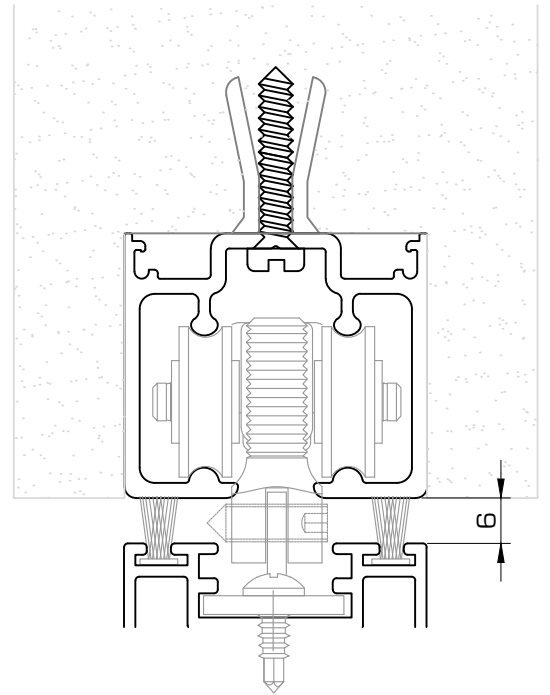
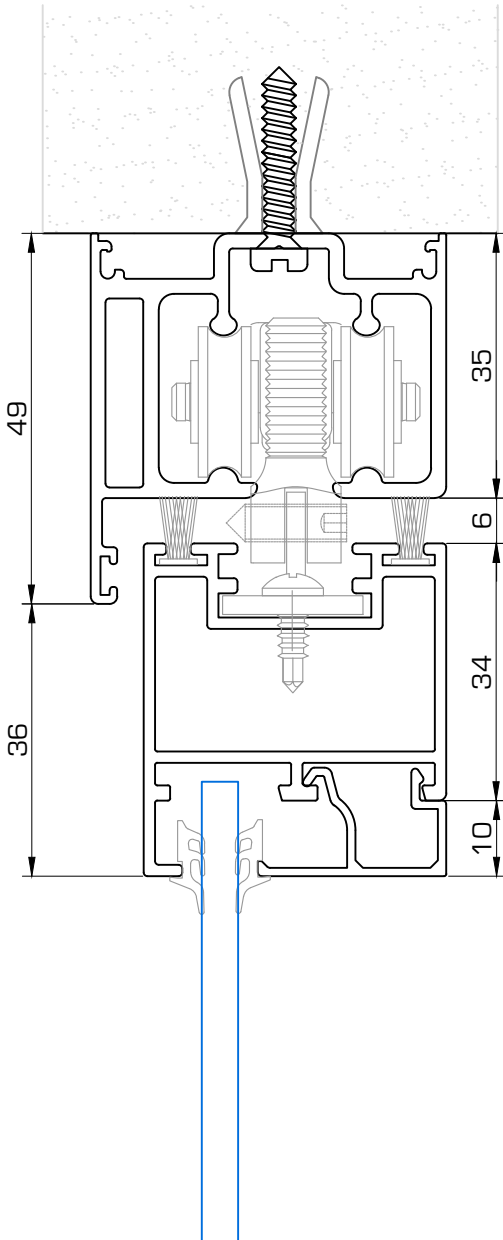
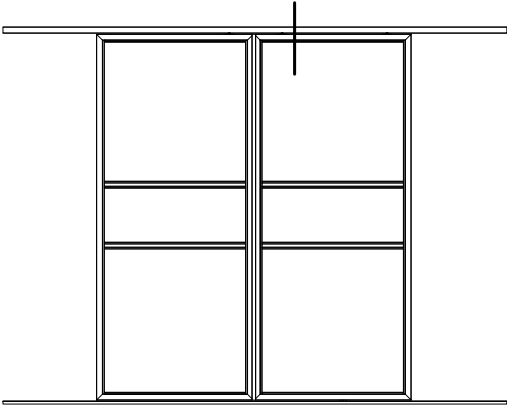

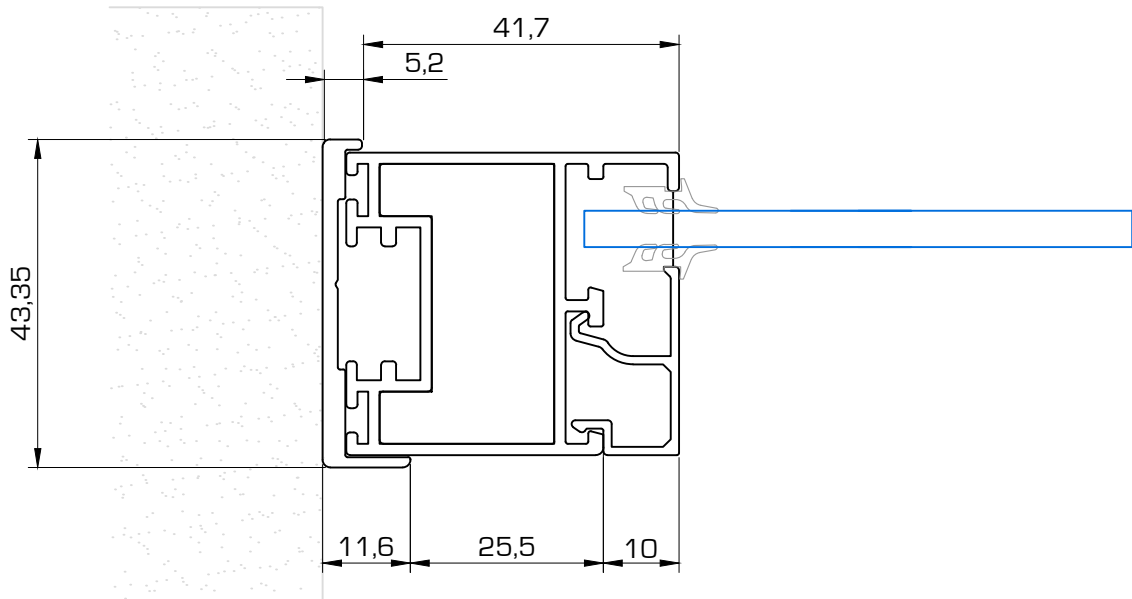
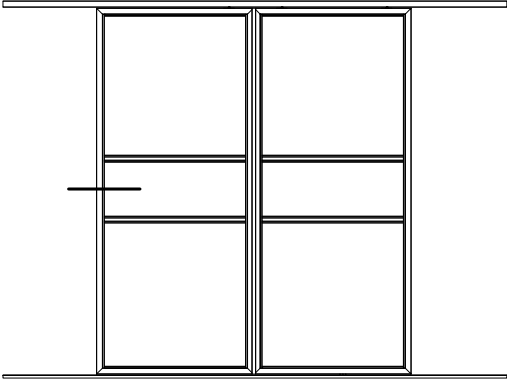

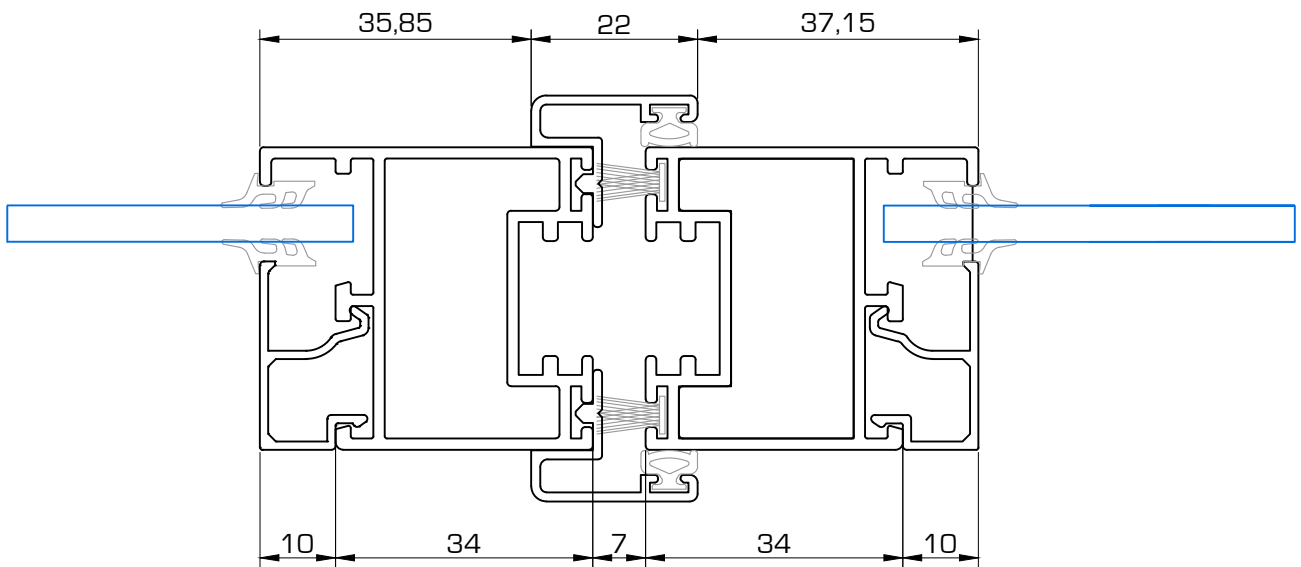
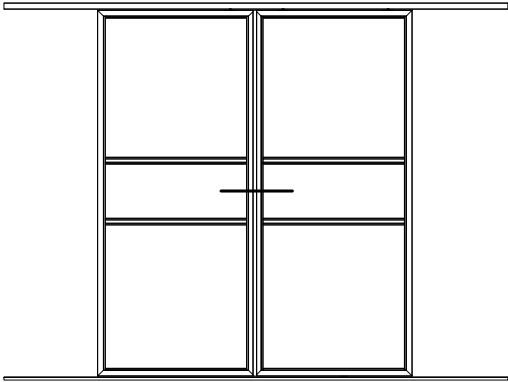

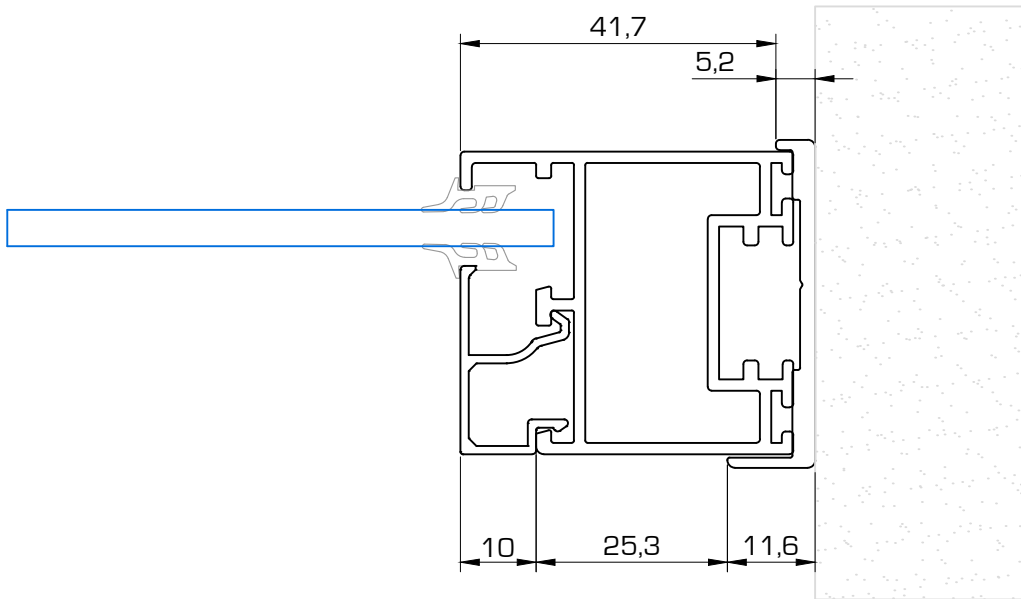
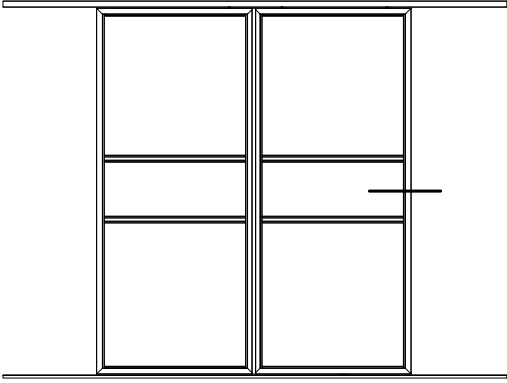

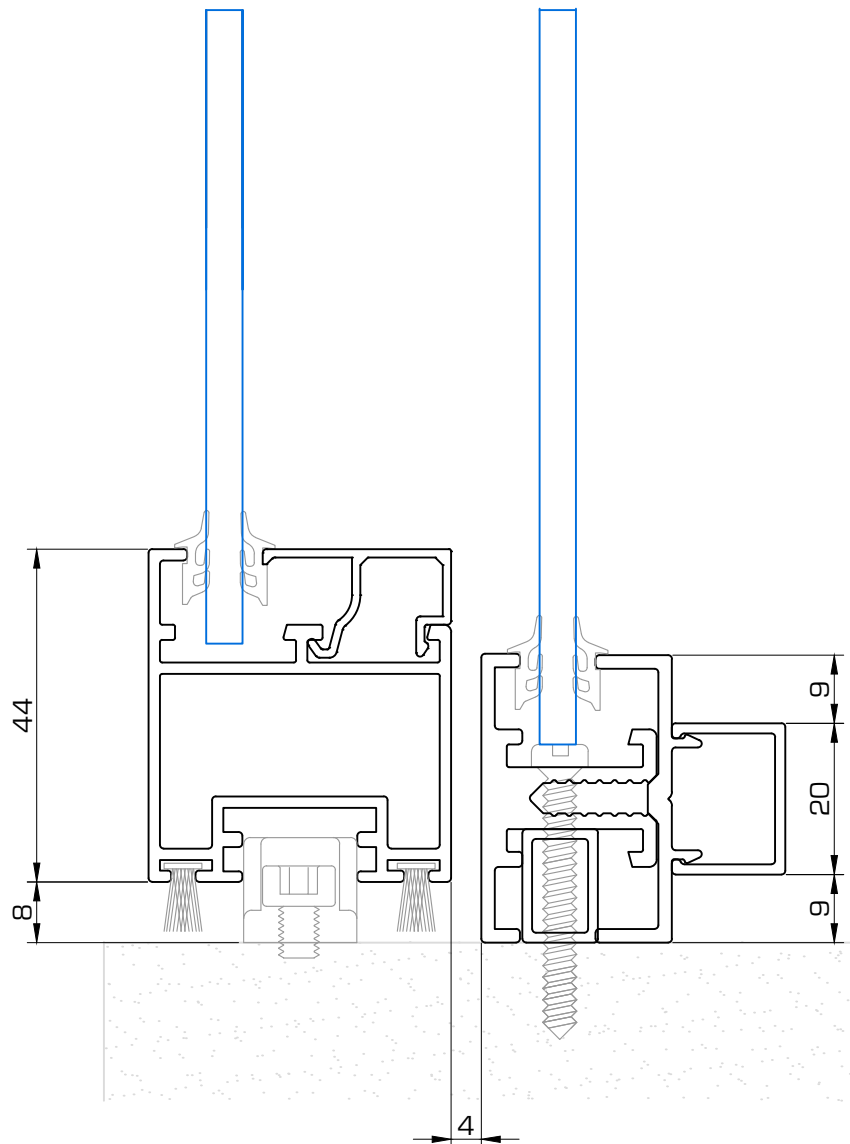
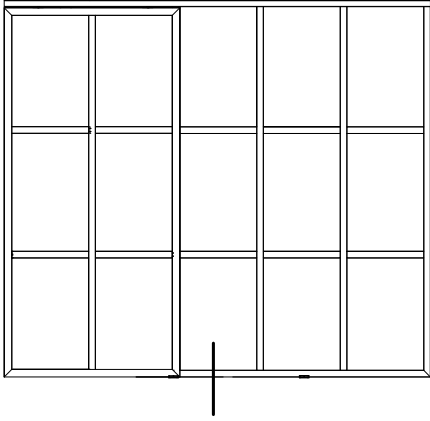

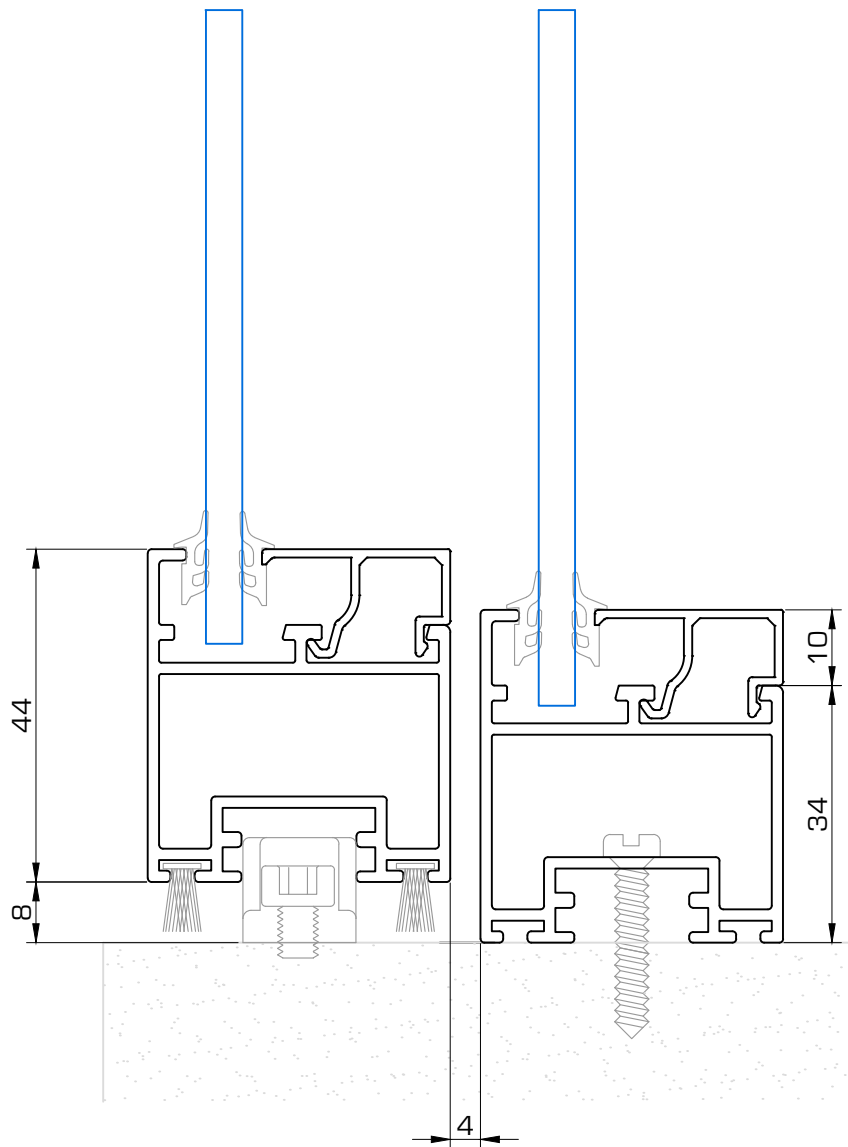
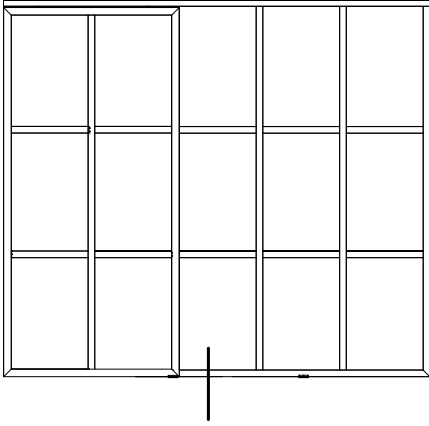

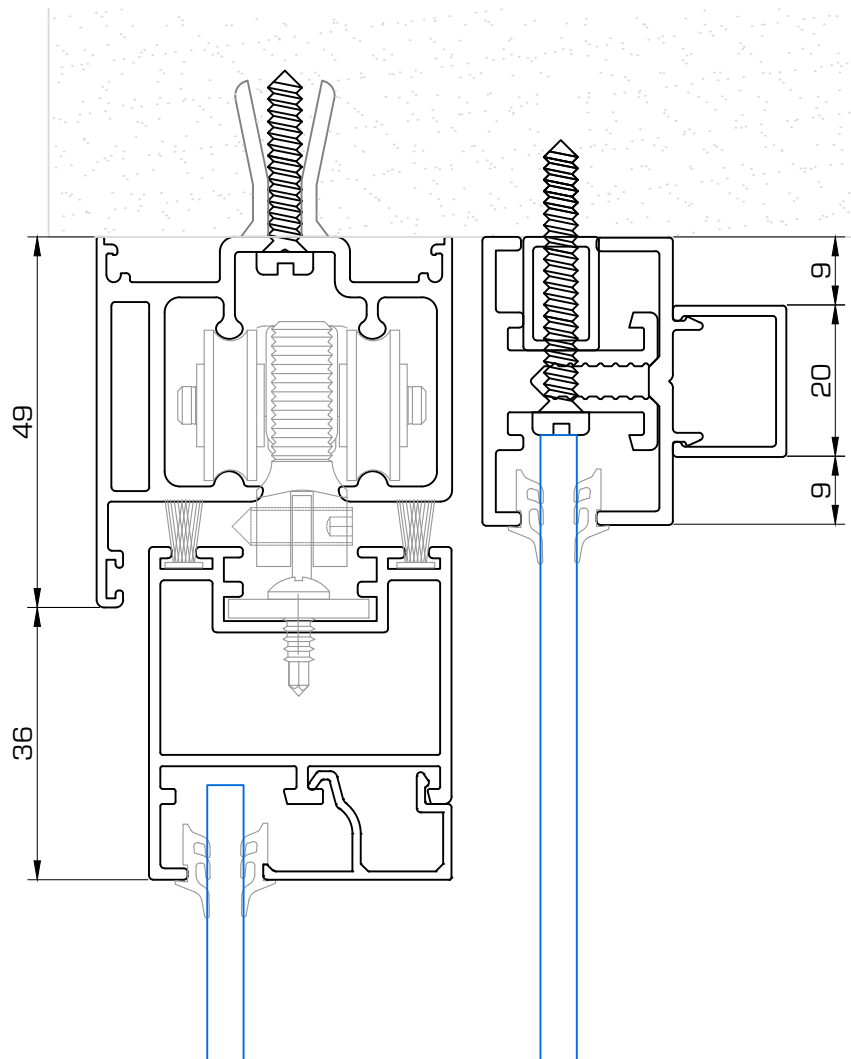
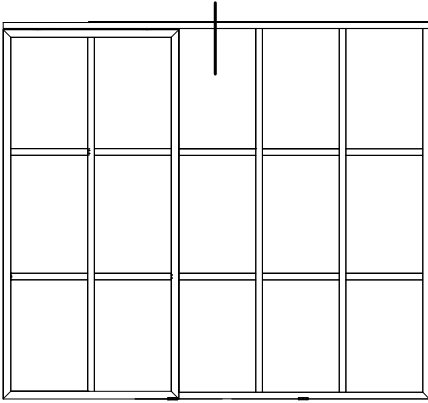

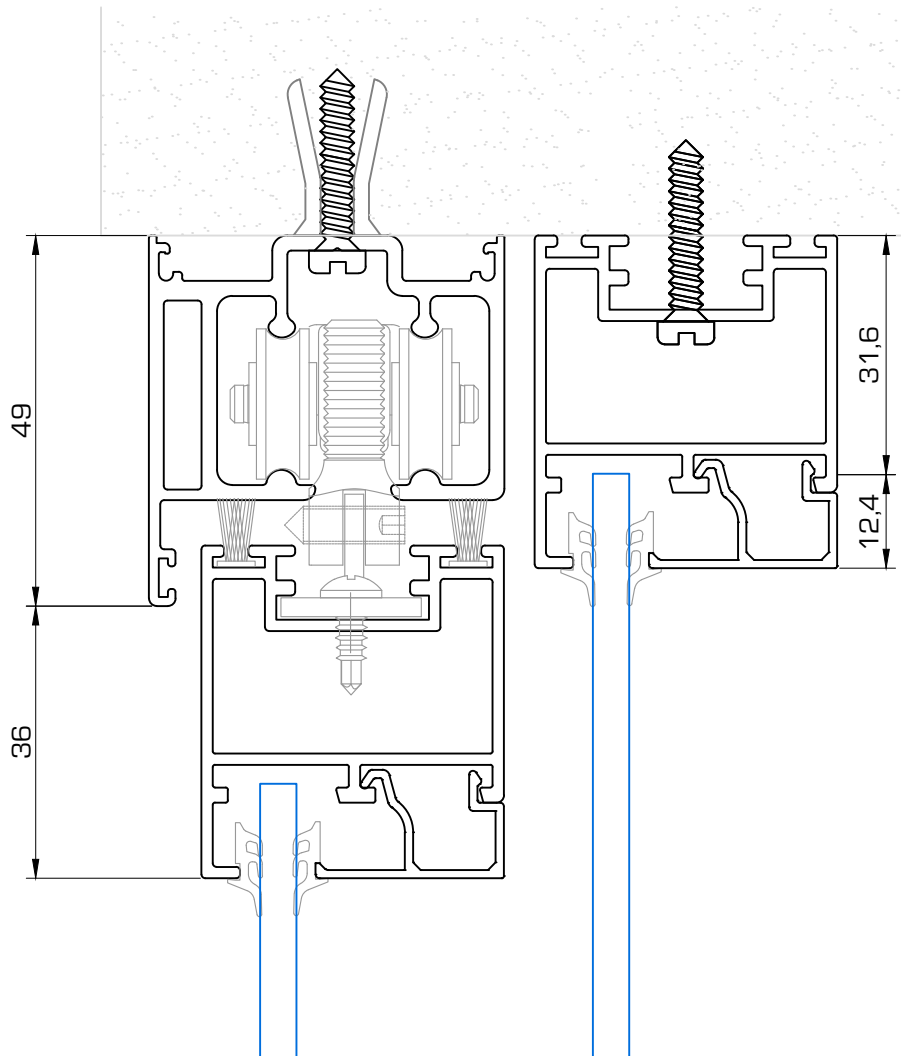
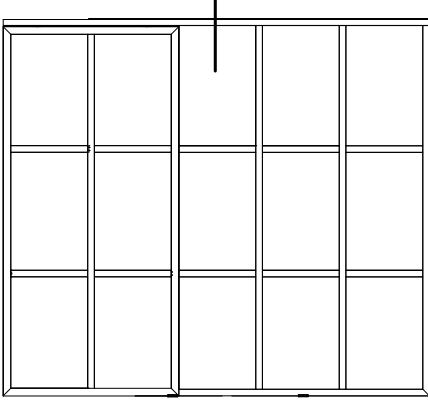

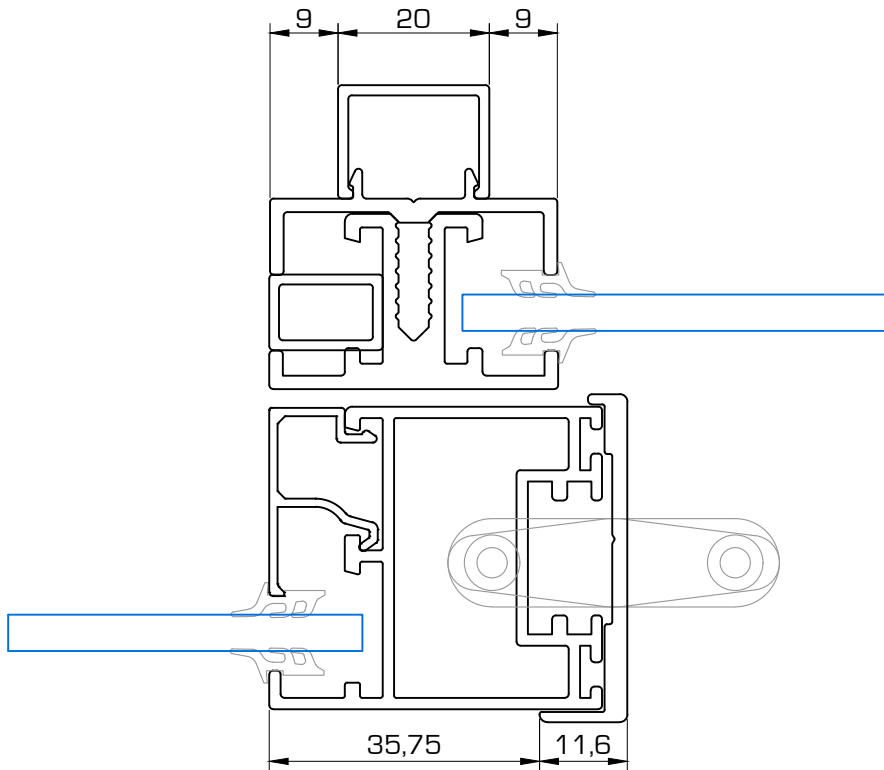
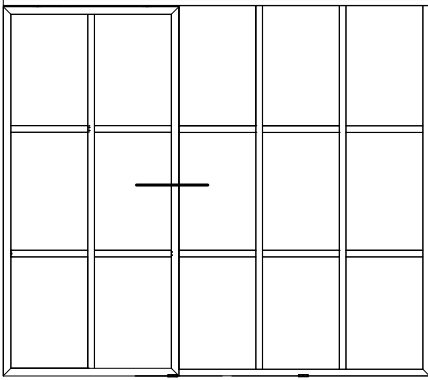

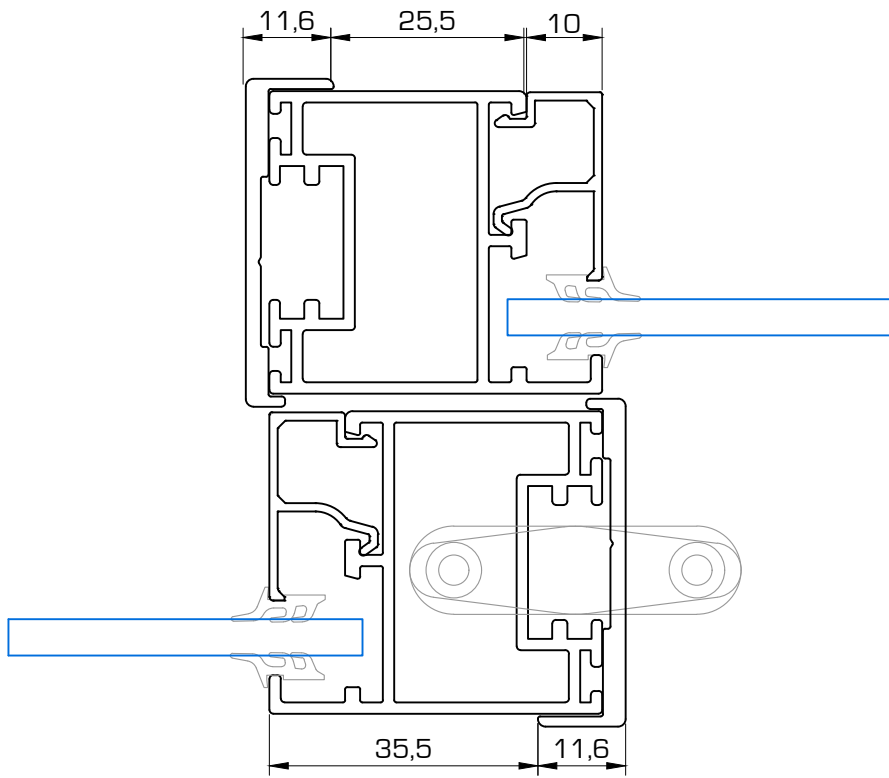
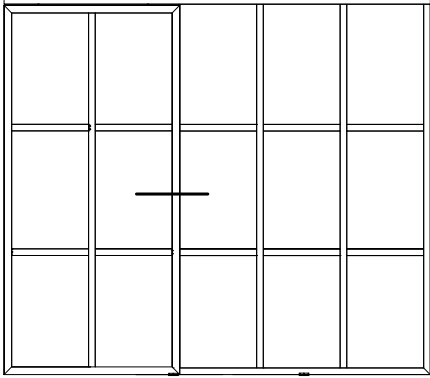

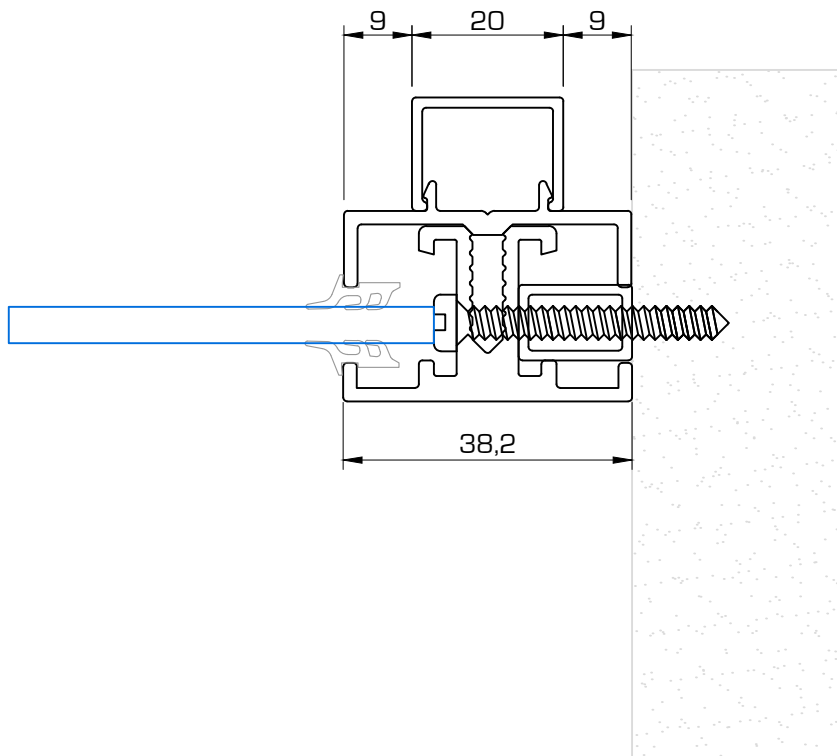
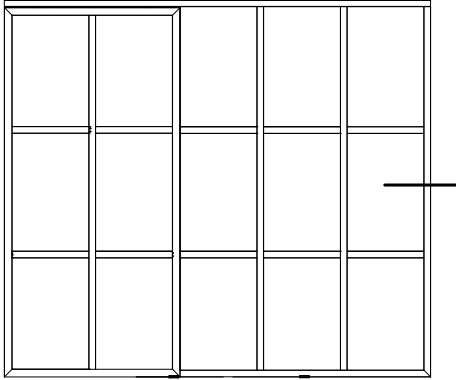

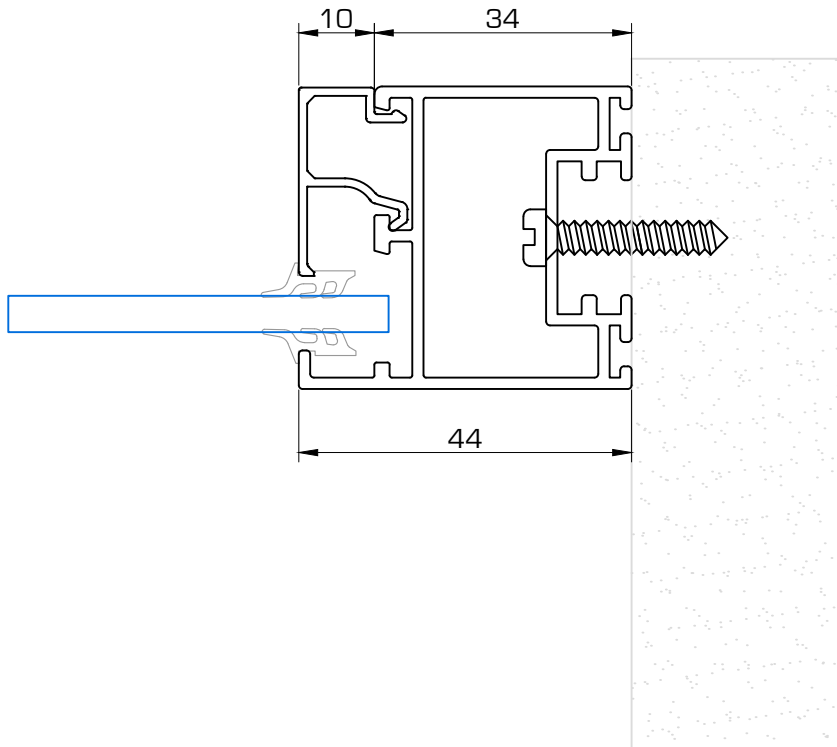
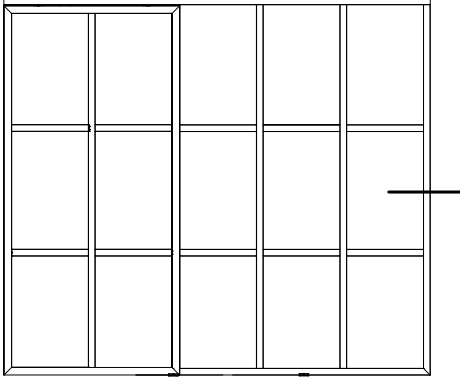

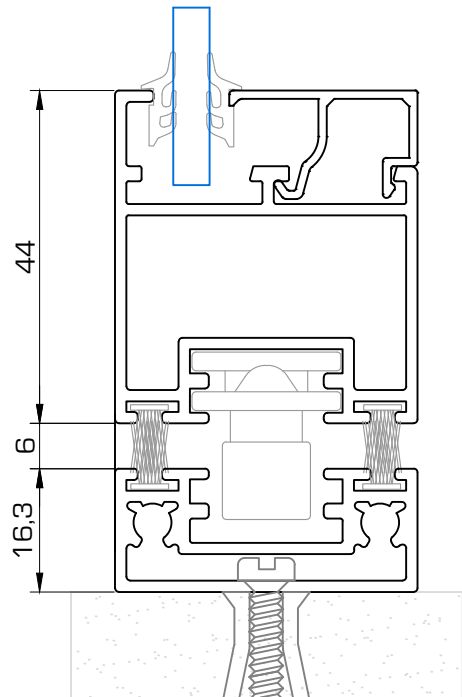
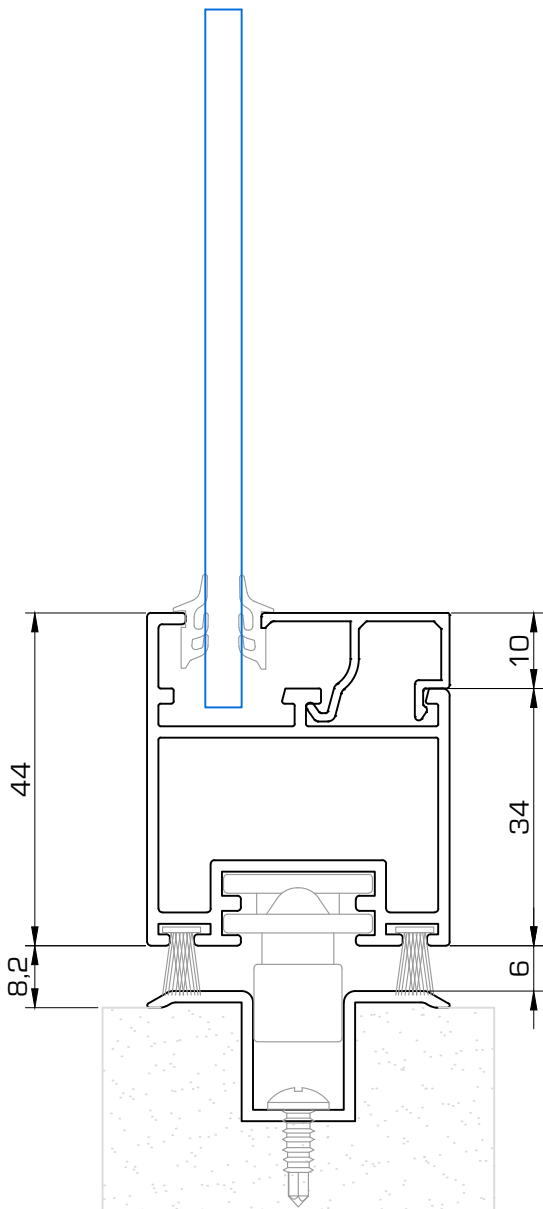
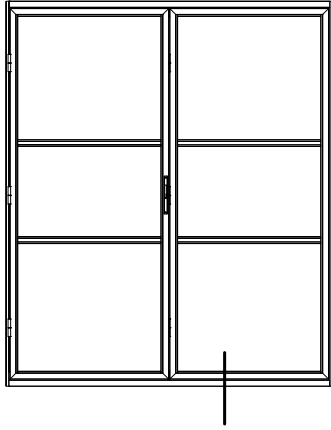

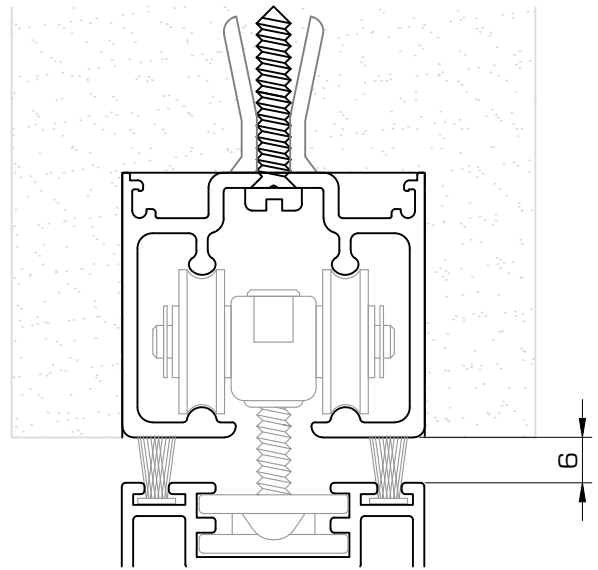
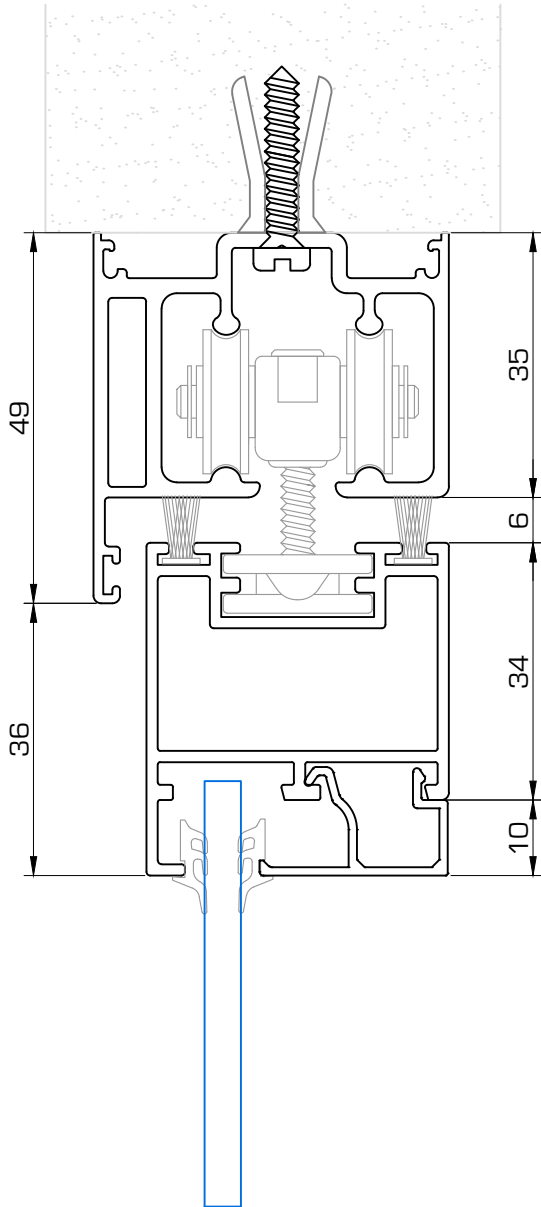
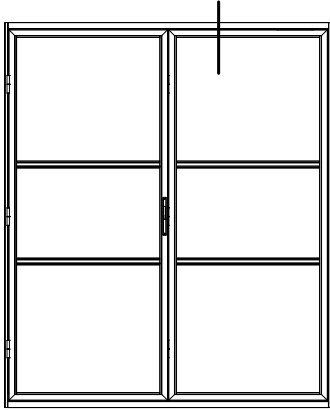

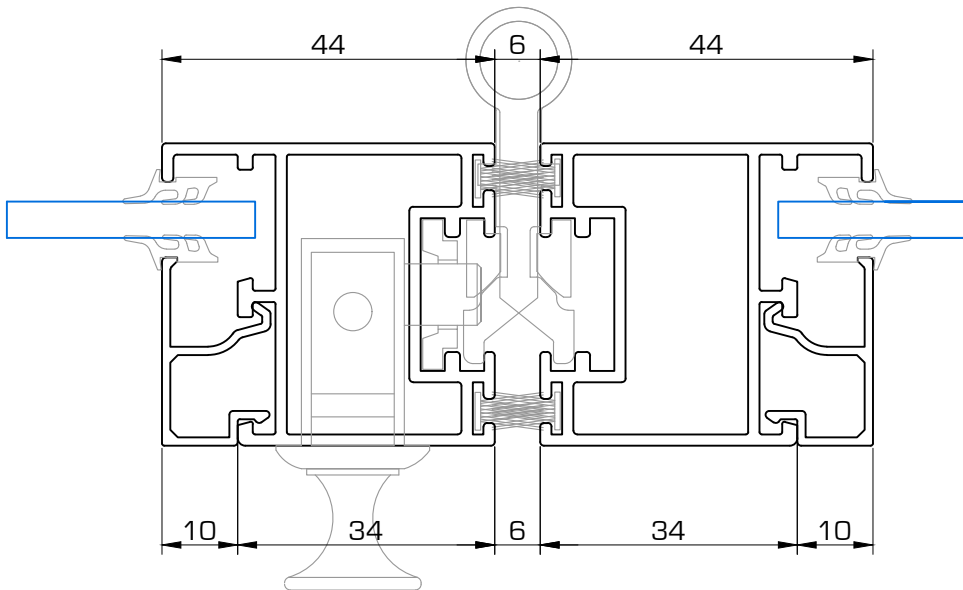
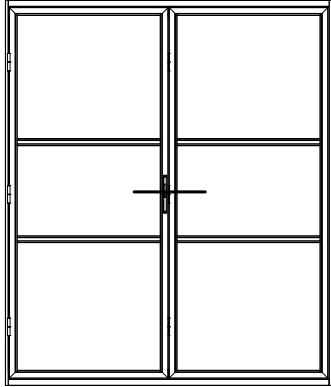

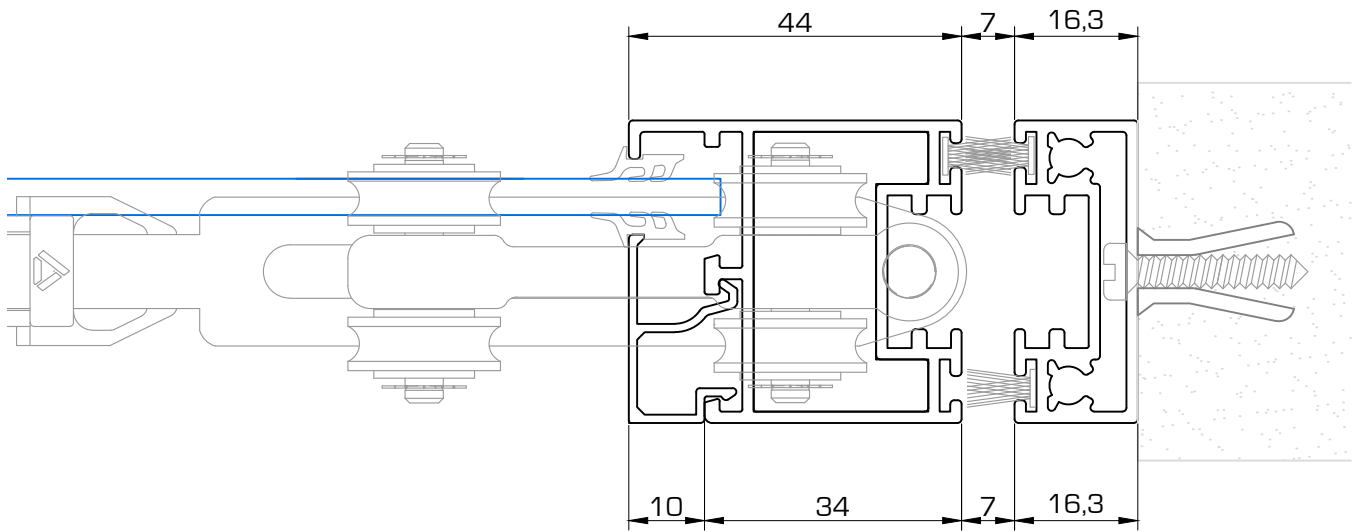
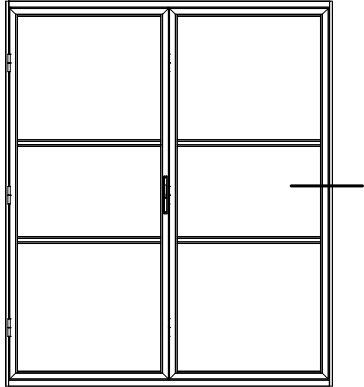

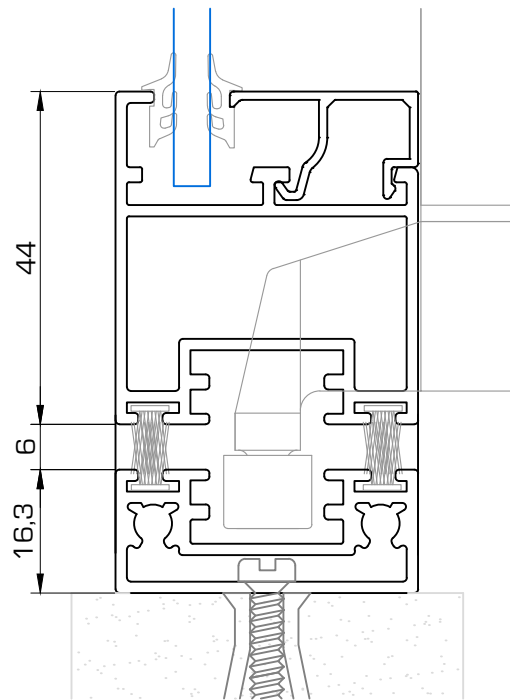
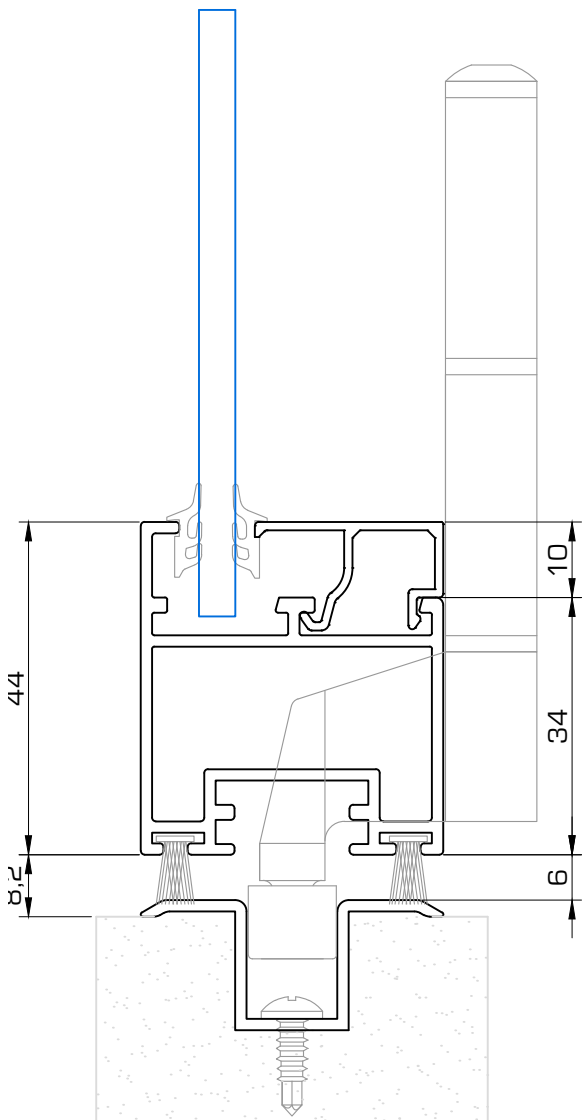
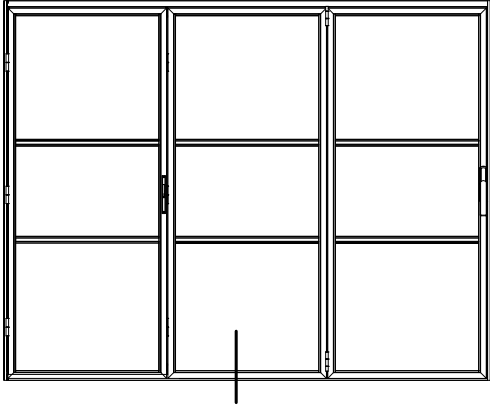

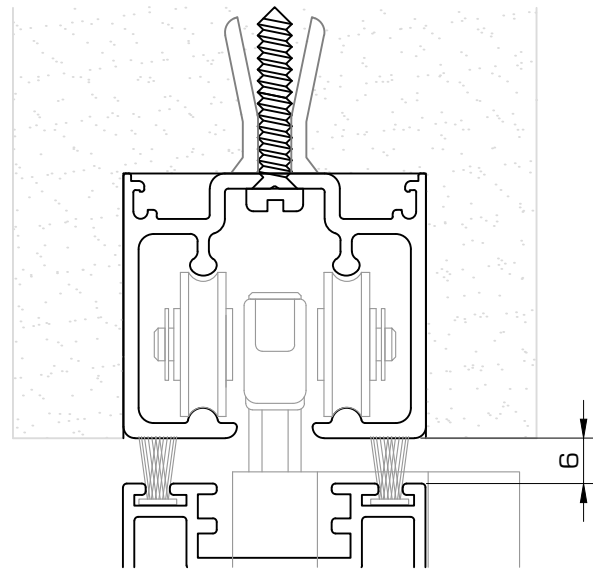
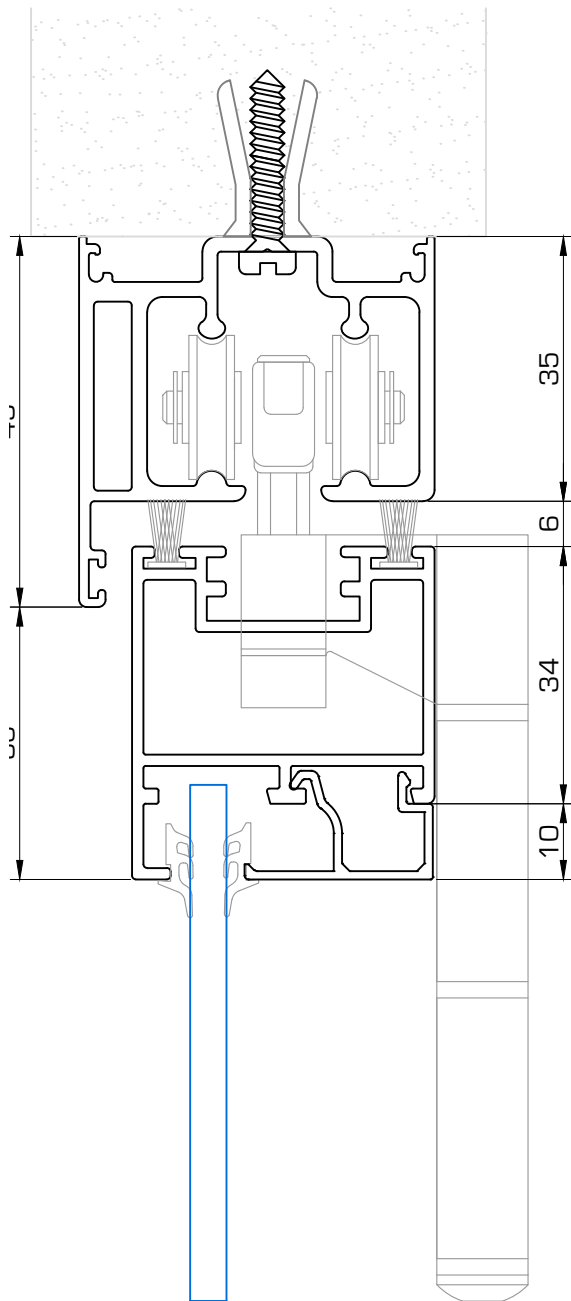
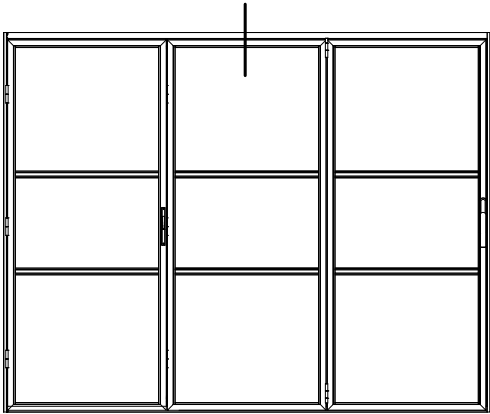

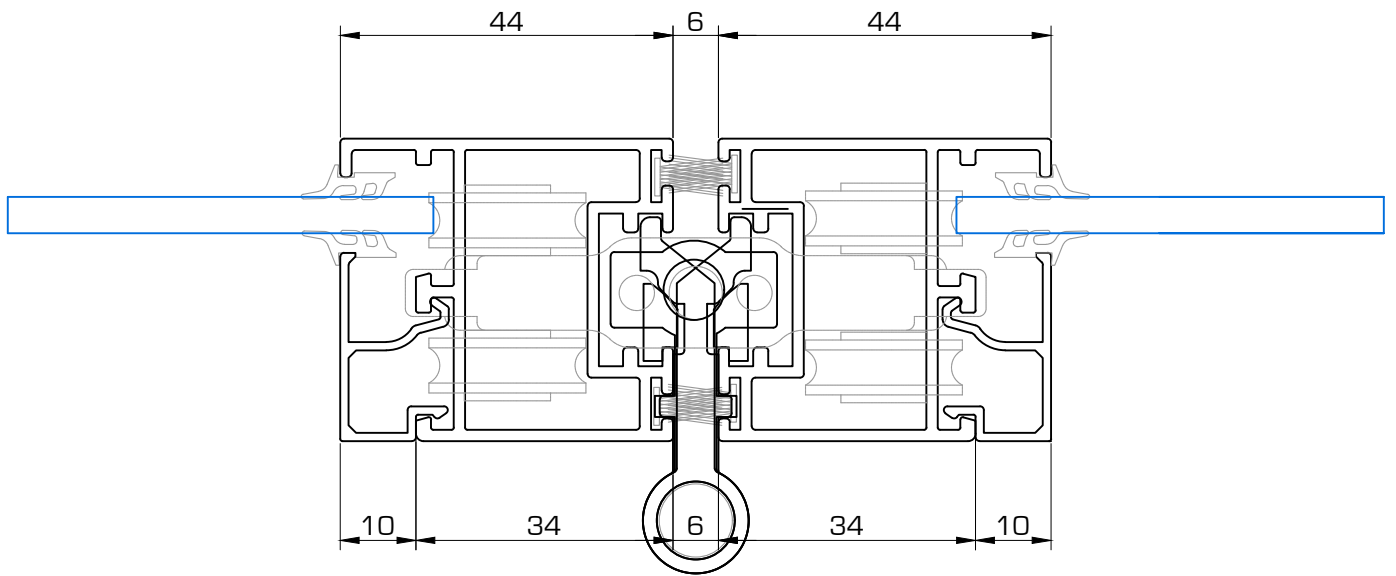
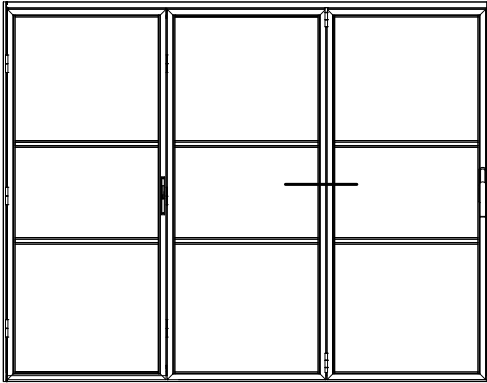

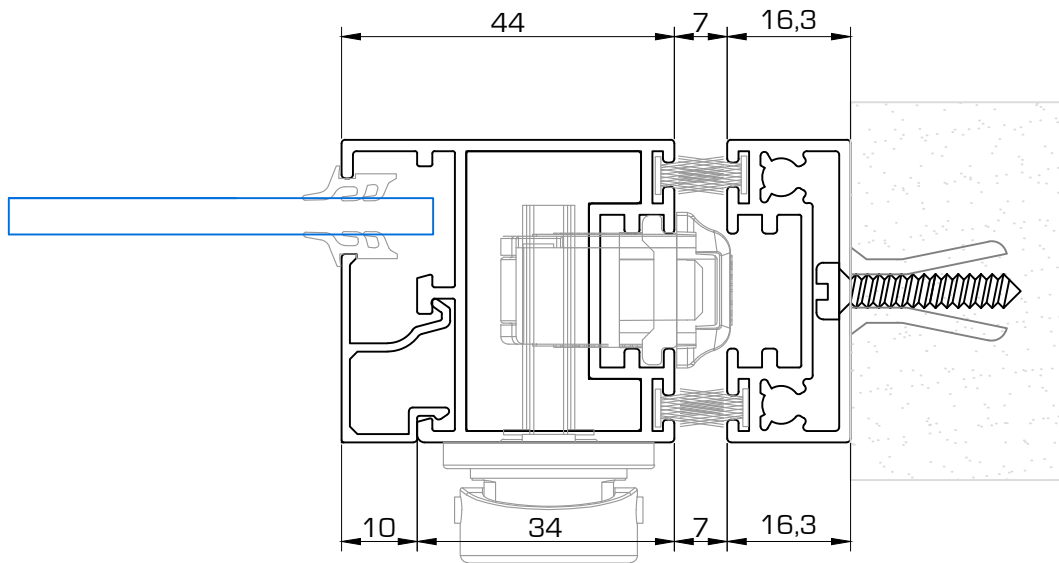
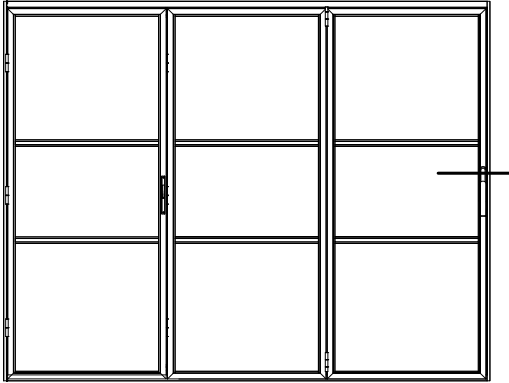

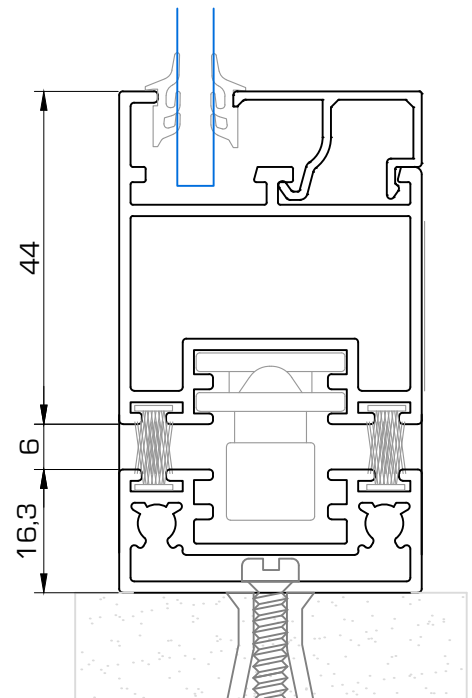
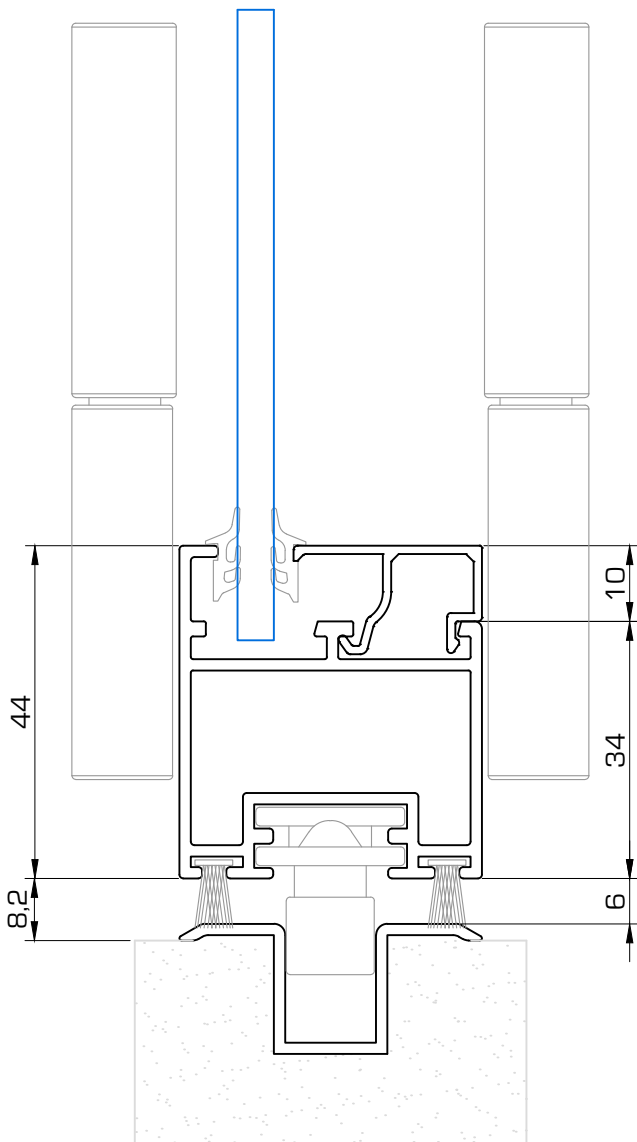
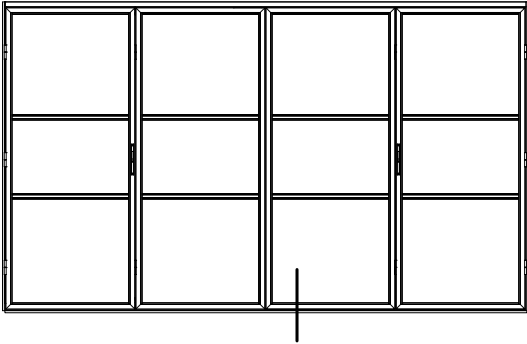

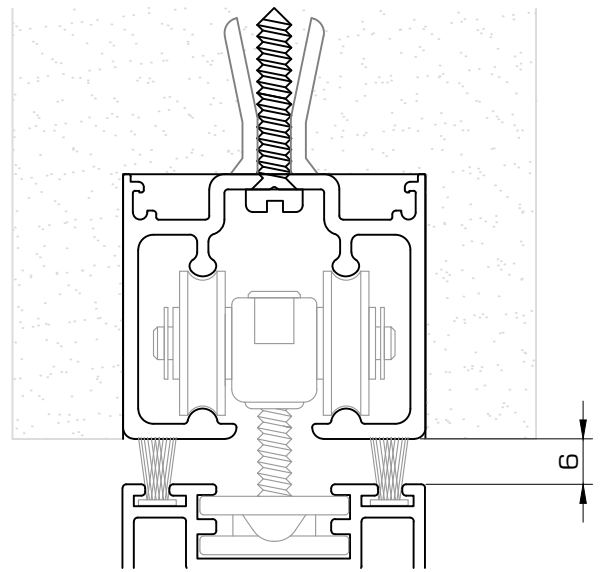
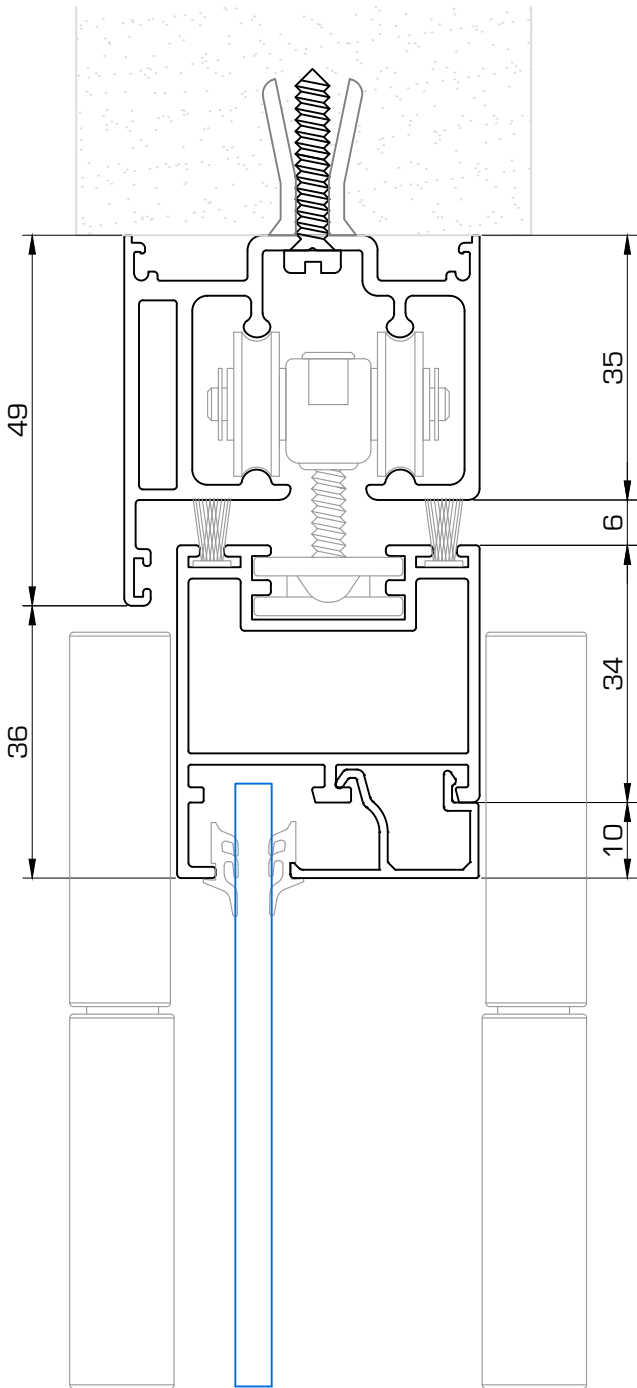
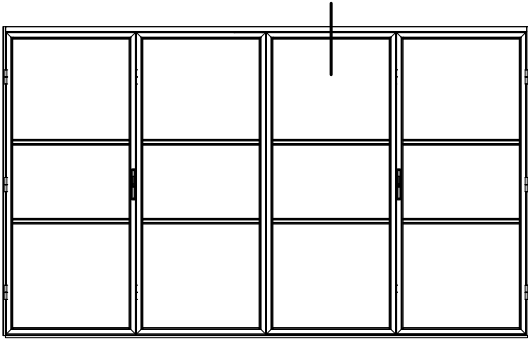

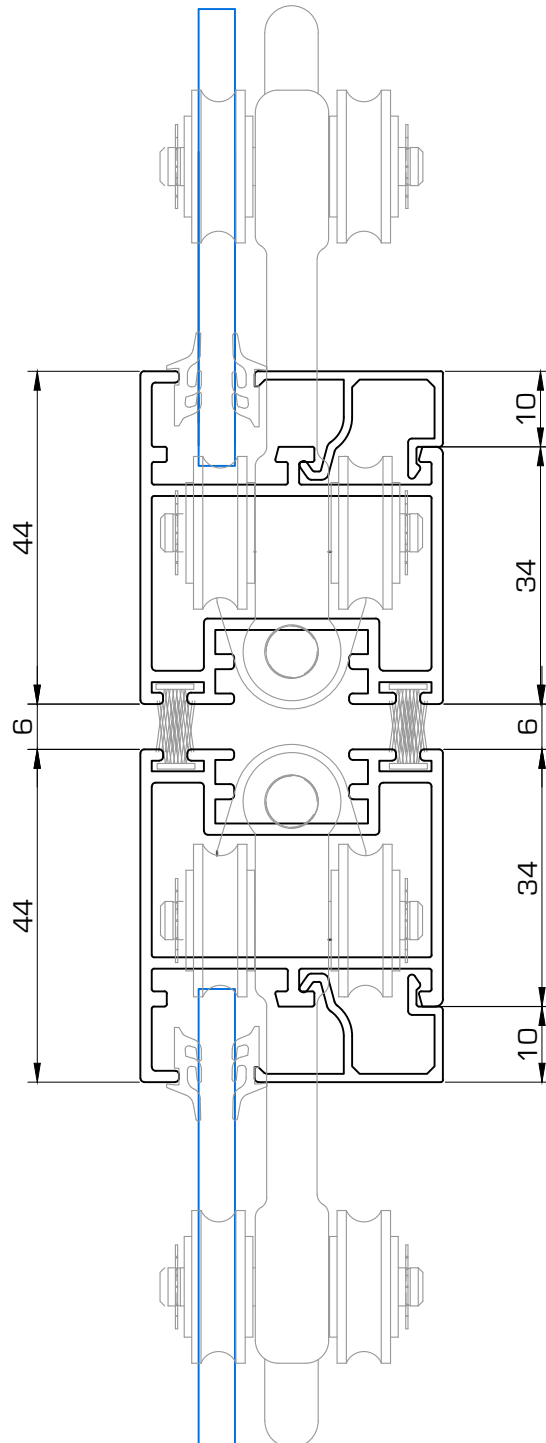
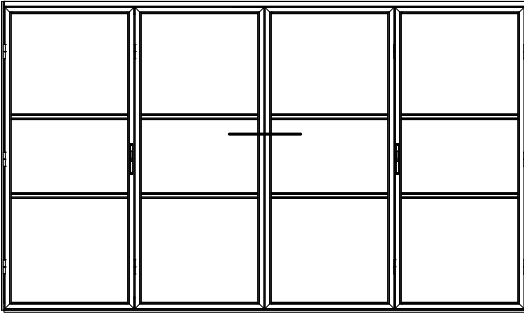

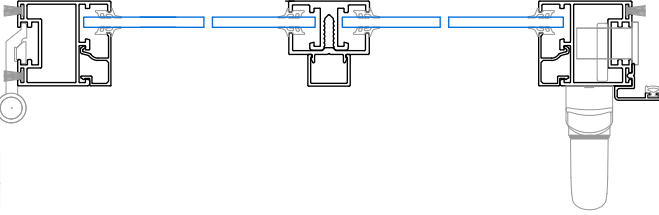
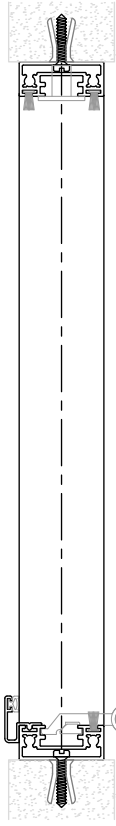

Ref.	Dibujo	Descripción	Contra	Ufcs	Descuento
7610		Marco horizontal		2	L
7607		Marco vertical		2	H - 52
7607		Hoja horizontal		2	L - 46
7607		Hoja vertical		2	H - 46

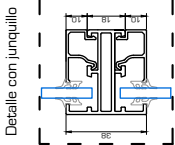
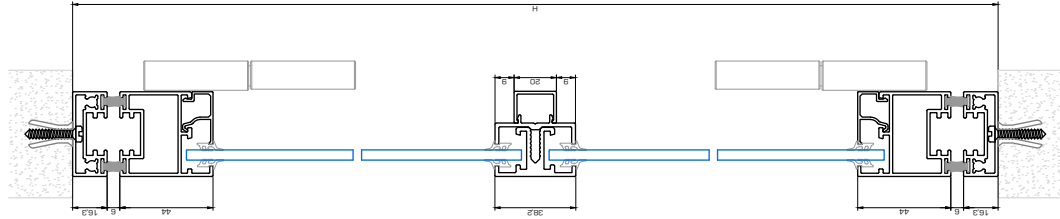
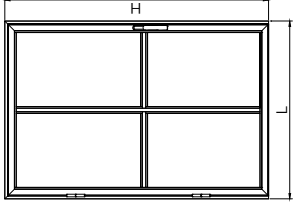

Detalle con junquillo

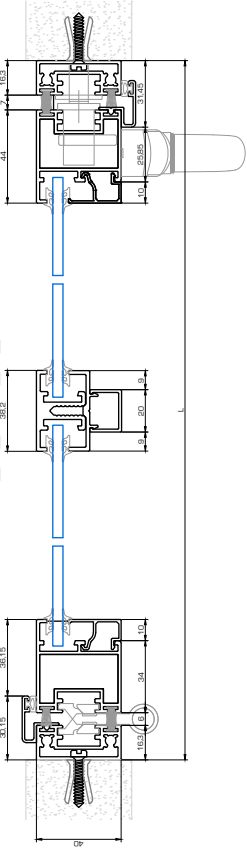
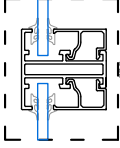

SECCIÓN ABATIBLE 2 HOJAS

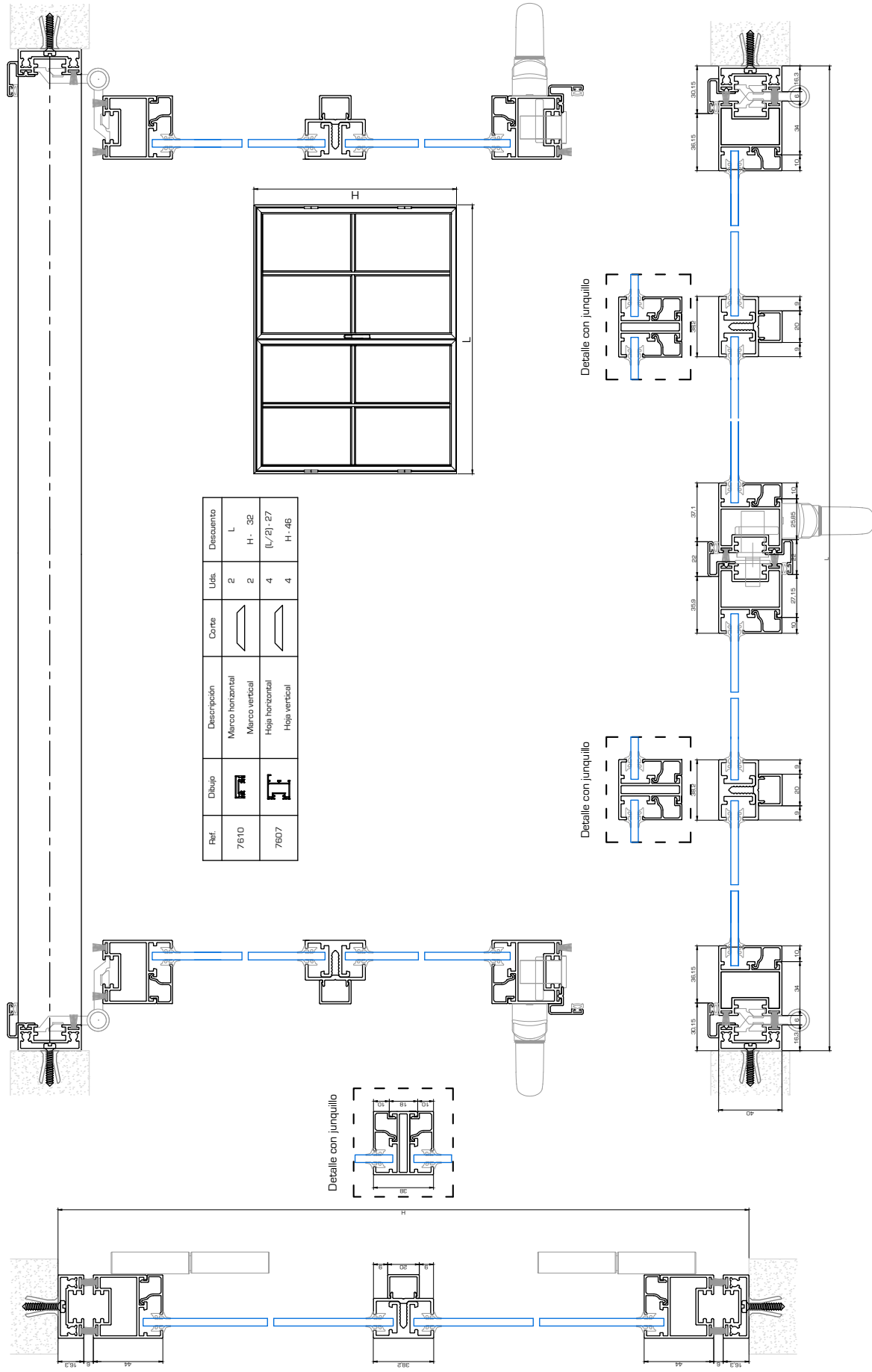

Ref.	Dibujo	Descripción	Corte.	Uds.	Desplazamiento
7610		Marco horizontal		2	L
		Marco vertical		2	H - 32
7607		Hoja horizontal		4	(L/2) - 27
		Hoja vertical		4	H - 46

Detalle con junquillo

Detalle con junquillo

Detalle con junquillo

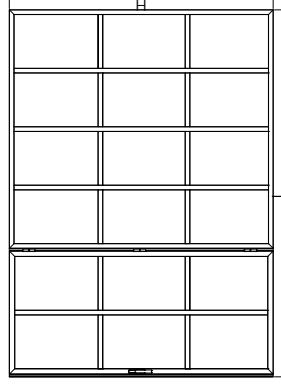

ABATIBLE				
Ref.	Dibujo	Descripción	Corte	Descuento
7610		Marco horizontal		L
		Marco vertical		H - 32
7607		Hoja horizontal		L - 46
		Hoja vertical		H - 46

FIJO CON JUNQUILLO				
Ref.	Dibujo	Descripción	Corte	Descuento
7607		Hoja horizontal		Fijo variable
		Hoja vertical		H

FIJO INDUSTRIAL				
Ref.	Dibujo	Descripción	Corte	Descuento
7620		Plisera industrial horz.		Fijo variable
		Plisera industrial vert.		H
7621		Perfil int. industrial horz.		Fijo variable
		Perfil int. industrial vert.		H

Detalle con junquillo

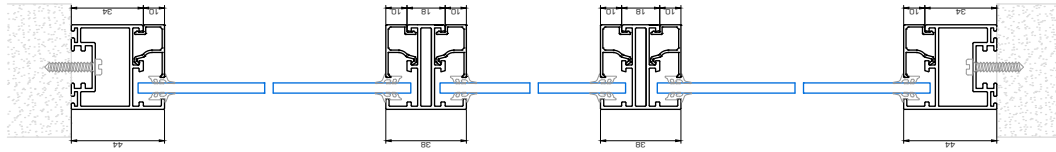

Detalle Industrial

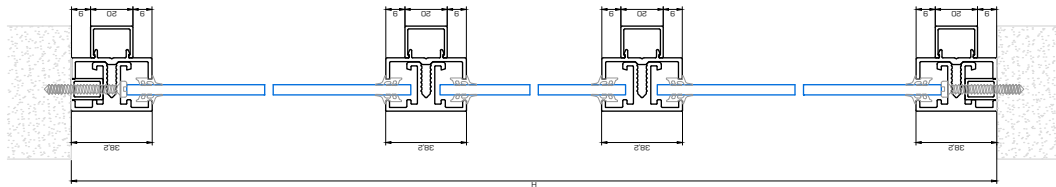

Detalle Industrial

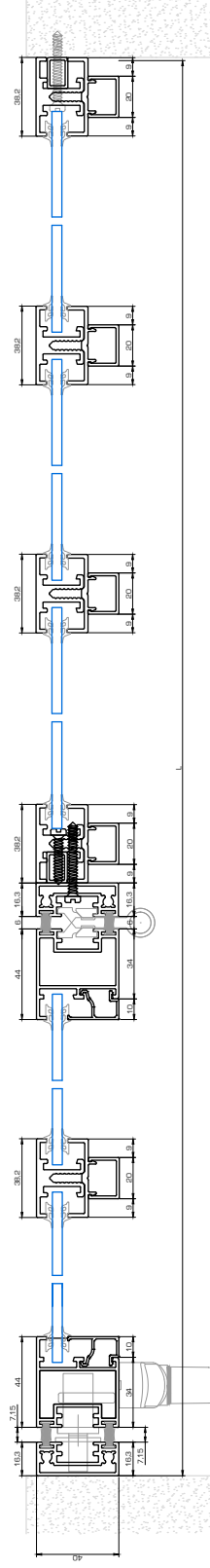

Detalle con junquillo

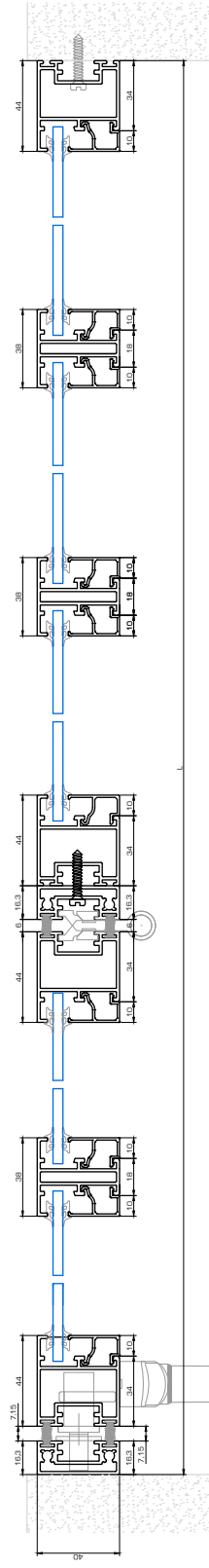

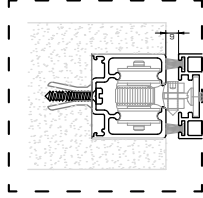

Detalle guía embutida

CON GUÍA SUPERIOR		DESCOLGADA			
Ref.	Dibujo	Descripción	Corte	Uds.	Descuento
481		Guía superior con ala		1	L
487		Guía inferior encastrada		1	L
7607		Hoja horizontal		4	(L/4)·2
		Hoja vertical		4	H·52

PERFIL LATERAL Y PERFIL BATEANTE OPCIONAL = H (alto de hoja)

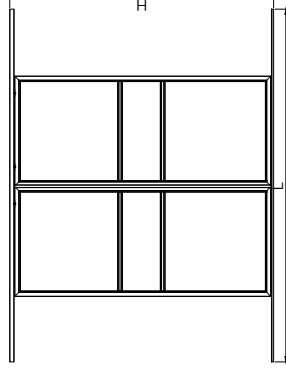

CON GUÍA SUPERIOR		EMBUJADA			
Ref.	Dibujo	Descripción	Corte	Uds.	Descuento
488		Guía superior sin ala		1	L
487		Guía inferior encastrada		1	L
7607		Hoja horizontal		4	(L/4)·2
		Hoja vertical		4	H·17

PERFIL LATERAL Y PERFIL BATEANTE OPCIONAL = H (alto de hoja)

Detalle con junquillo

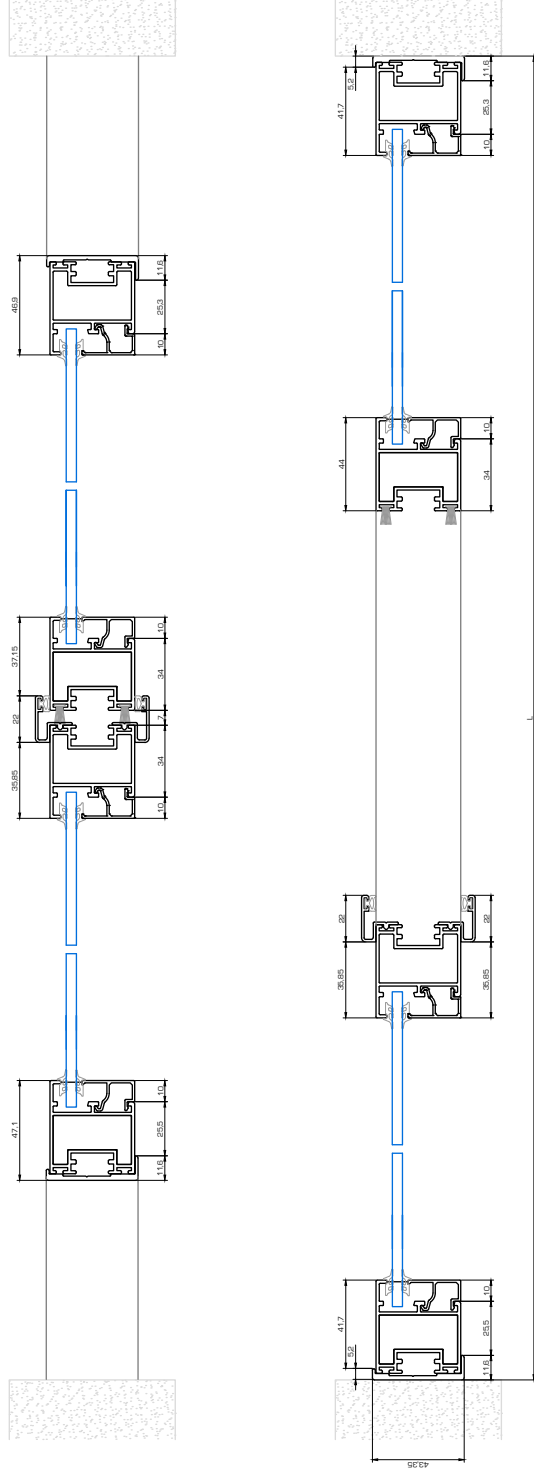
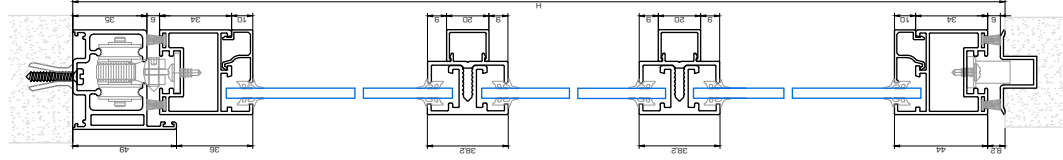
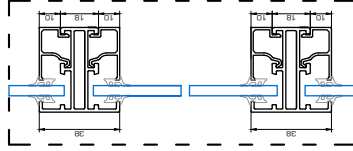

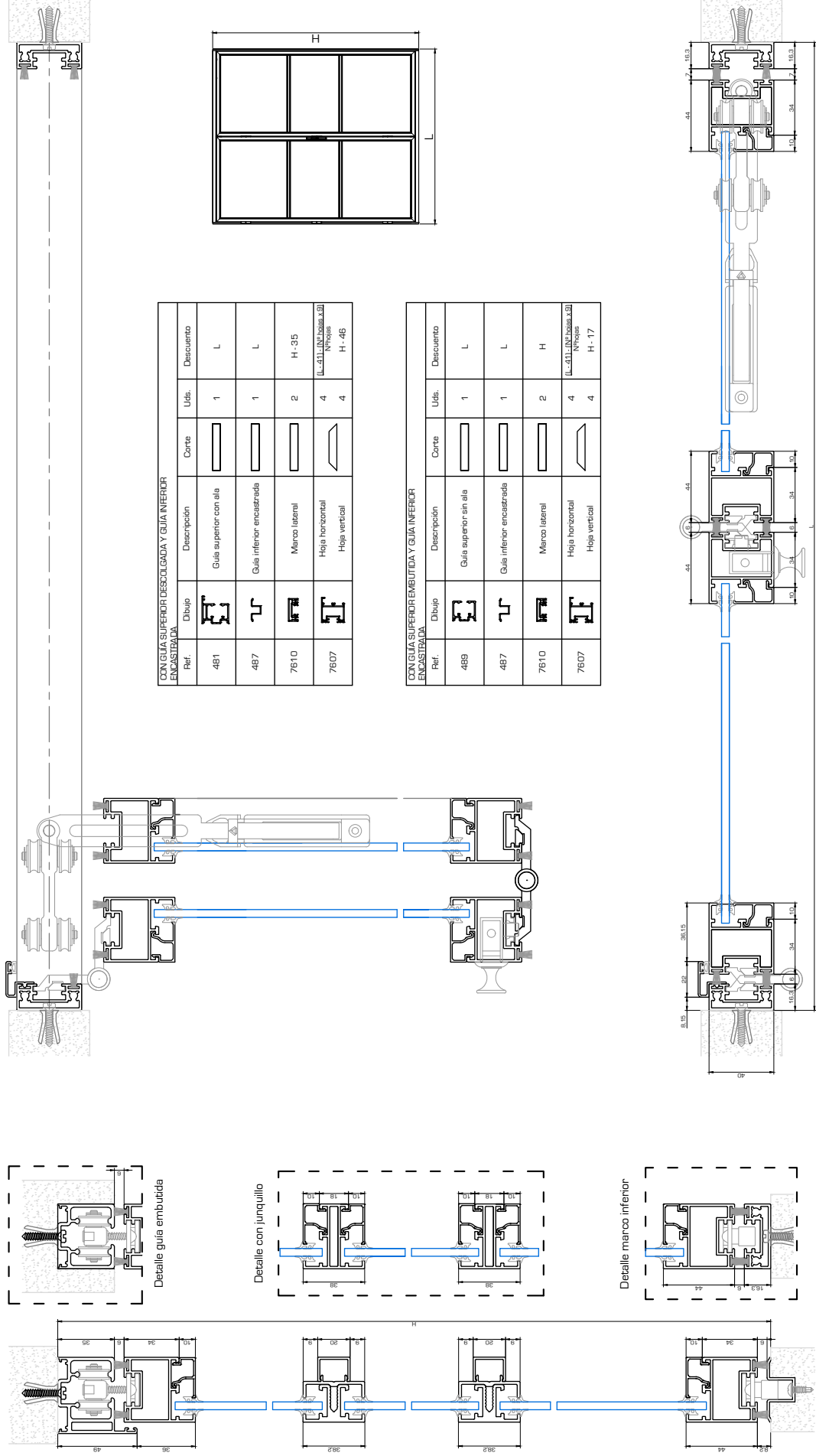

SECCIÓN REPLEGABLE 3 HOJAS

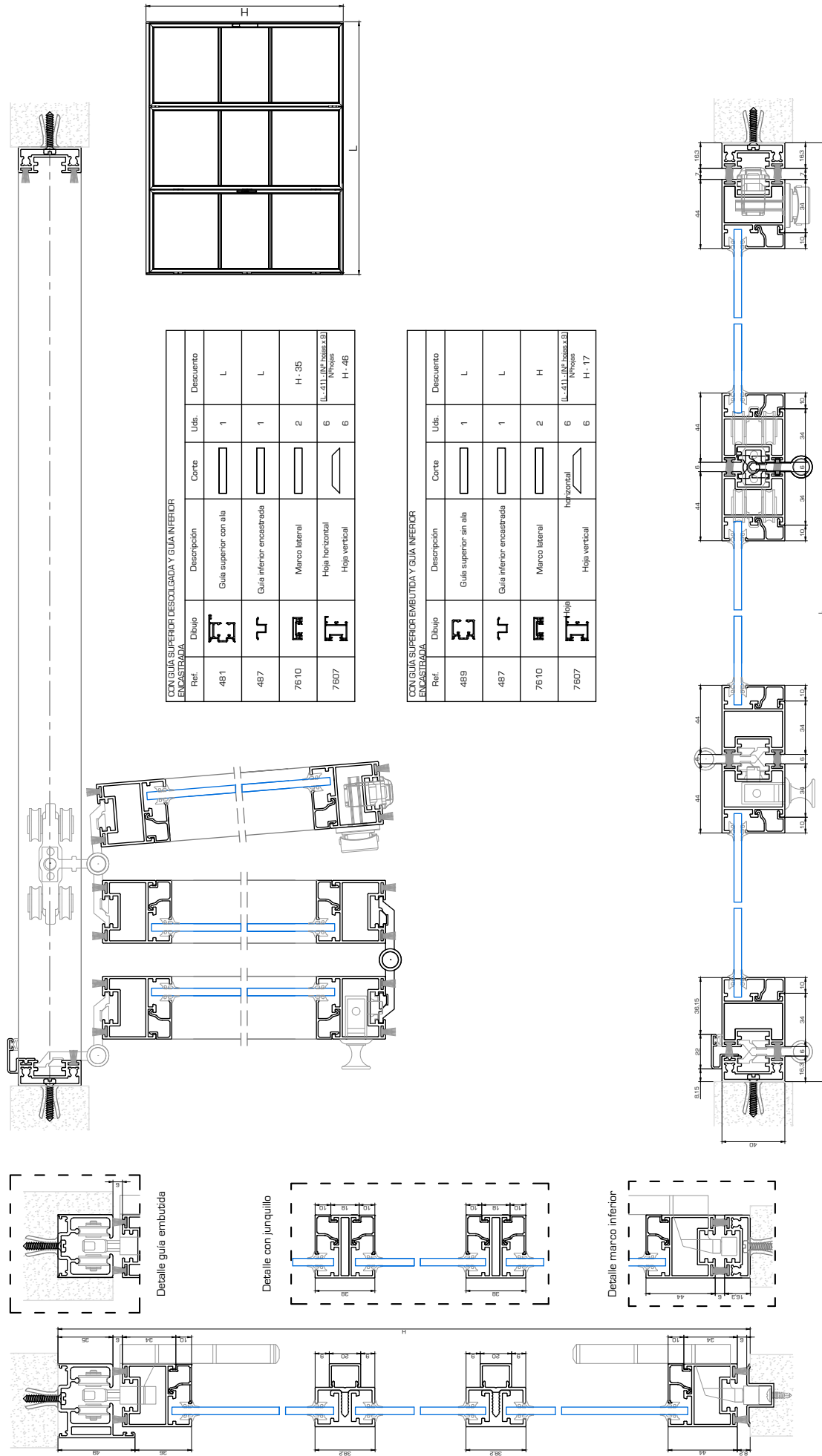

CON GUÍA SUPERIOR DESCOLGADA Y GUÍA INFERIOR ENCASTRADA

Ref.	Dibujo	Descripción	Corte	Uds.	Descuento
481		Guía superior con ala		1	L
487		Guía inferior encastrada		1	L
7610		Marco lateral		2	H - 35
7607		Hoja horizontal		6	(L-41) (NL base 2,3) NT hojas
		Hoja vertical		6	H - 46

CON GUÍA SUPERIOR EMBUTIDA Y GUÍA INFERIOR ENCASTRADA

Ref.	Dibujo	Descripción	Corte	Uds.	Descuento
489		Guía superior sin ala		1	L
487		Guía inferior encastrada		1	L
7610		Marco lateral		2	H
7607		horizontal		6	(L-41) (NL base 2,3) NT hojas
		Hoja vertical		6	H - 17

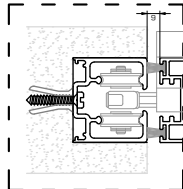

Detalle guía embutida

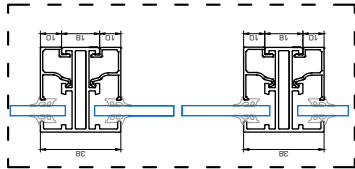

Detalle con junquillo

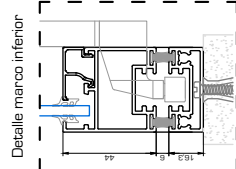

Detalle marco inferior

SECCIÓN REPLEGABLE 4 HOJAS

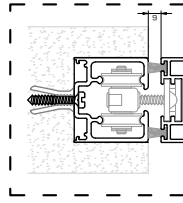
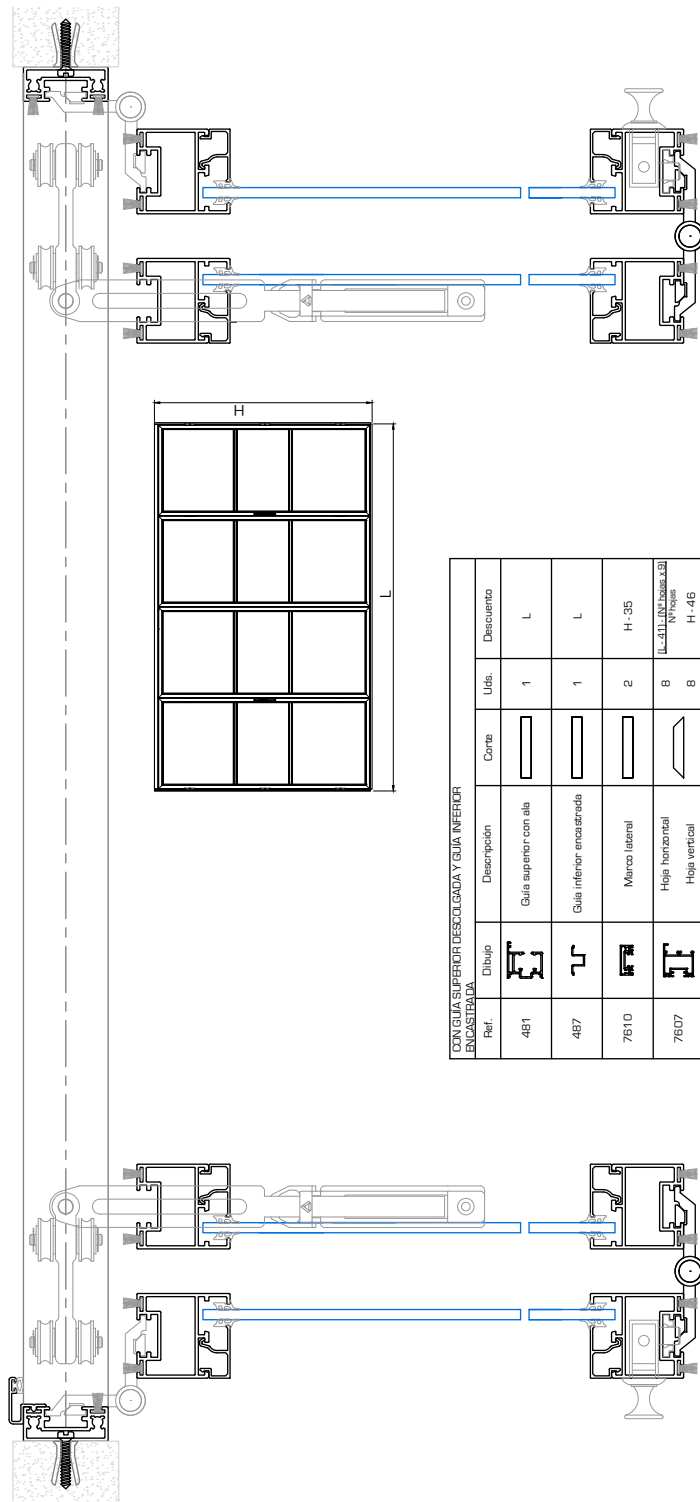

Detalle guía embudida

Detalle con jurquillo

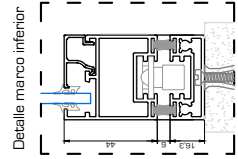
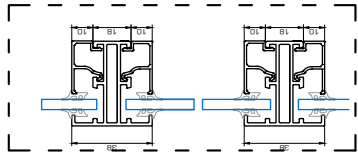

Detalle marco inferior

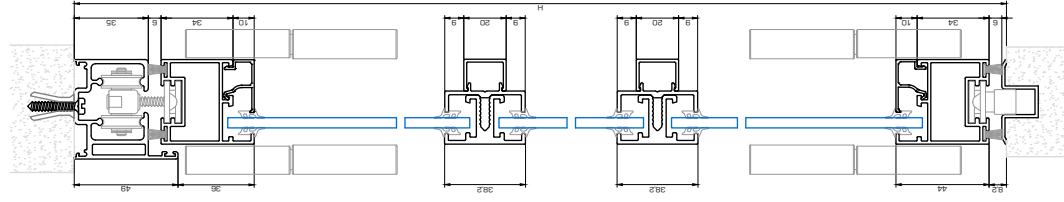

CON GUÍA SUPERIOR DESCOLGADA Y GUÍA INFERIOR ENCASTRADA

Ref.	Dibujos	Descripción	Comp.	Uds.	Descuento
481		Guía superior con alle		1	L
487		Guía inferior encastrada		1	L
7610		Marco lateral		2	H - 35
7607		Hoja horizontal		8	L - 41 (L x 2 hojas x 2)
		Hoja vertical		8	H - 46

CON GUÍA SUPERIOR EMBUTIDA Y GUÍA INFERIOR ENCASTRADA

Ref.	Dibujos	Descripción	Comp.	Uds.	Descuento
489		Guía superior sin alle		1	L
487		Guía inferior encastrada		1	L
7610		Marco lateral		2	H
7607		Hoja horizontal		8	L - 41 (L x 2 hojas x 2)
		Hoja vertical		8	H - 17

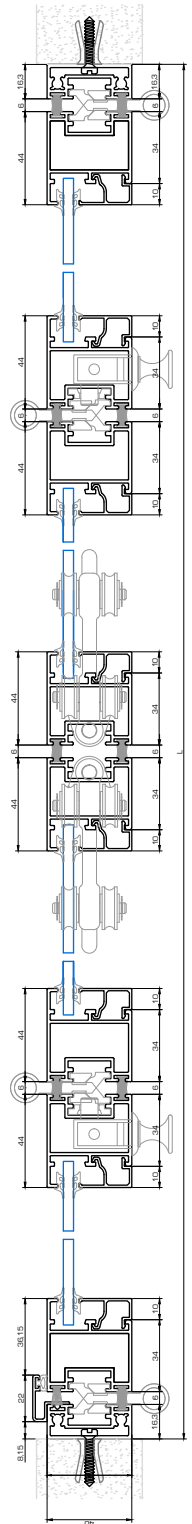

Escuadra de alineación interior

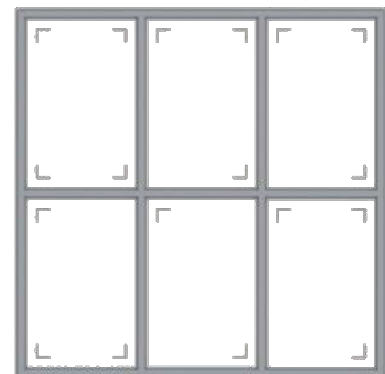

Escuadra de alineación exterior



Detalle con escuadras montadas

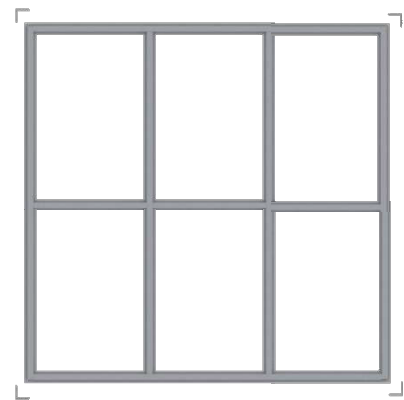

Ejemplo montaje ES 2601

Rebaje del perfil GP-7520



Dimensiones de corte aproximadas (mm)

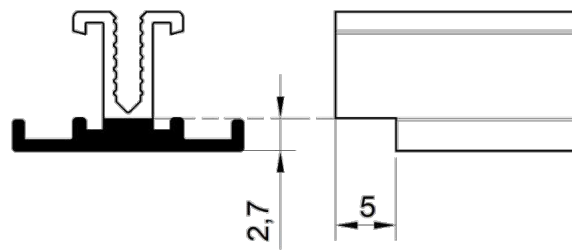

Rebaje del perfil GP-7521



Dimensiones de corte aproximadas (mm)

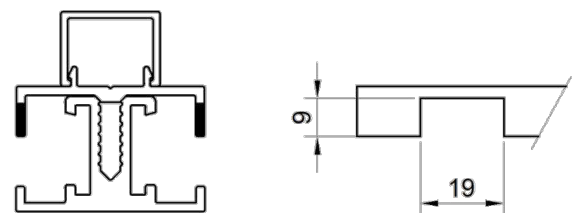

Guía superior con ala - Corte recto



Anclaje guía superior con marco lateral



Anclaje directo a pared

Guía superior encastrada - Corte recto



Anclaje directo a pared

Final de carrera

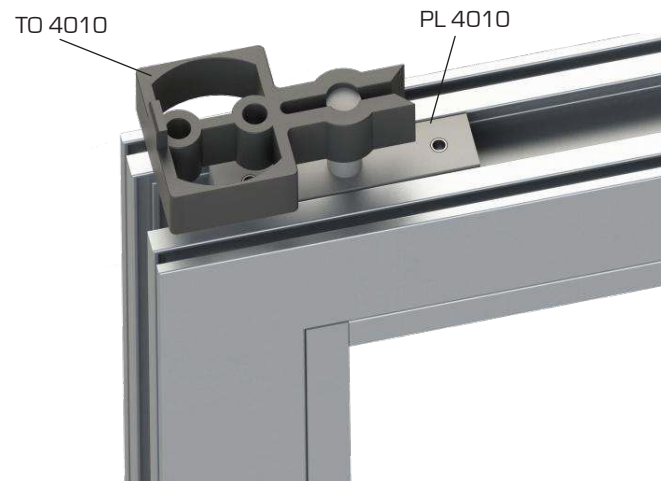

Pasador y pomo

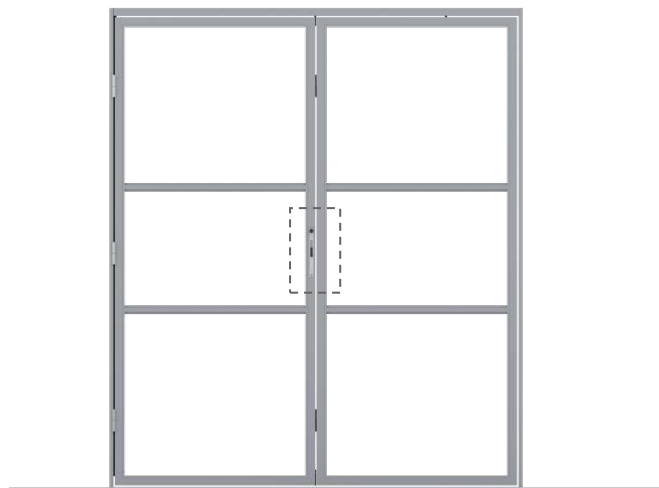
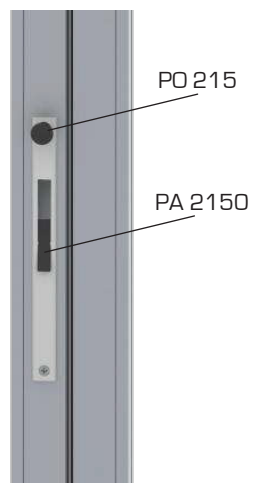

Guía superior con ala – Rodamiento corredera extramuros

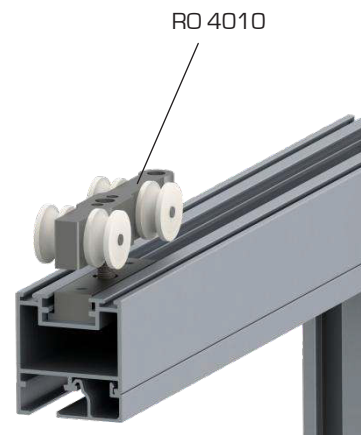

Guía superior encastrada – Rodamiento corredera extramuros

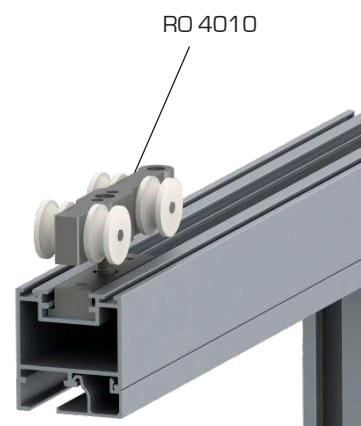

Guía inferior encastrada – Patín guiado



Sin guía inferior – Patín sobrepuesto

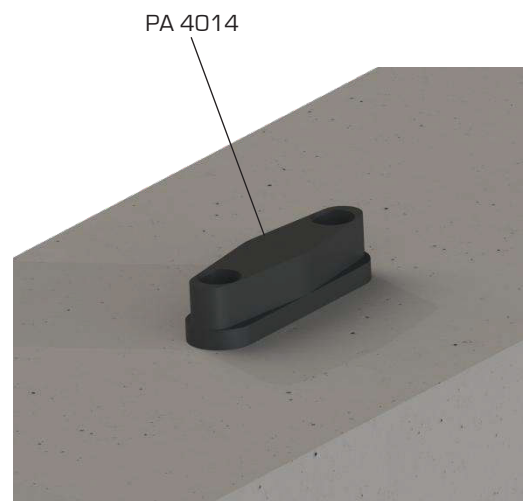

Guía superior con ala - Rodamiento Superior Hojas Pares

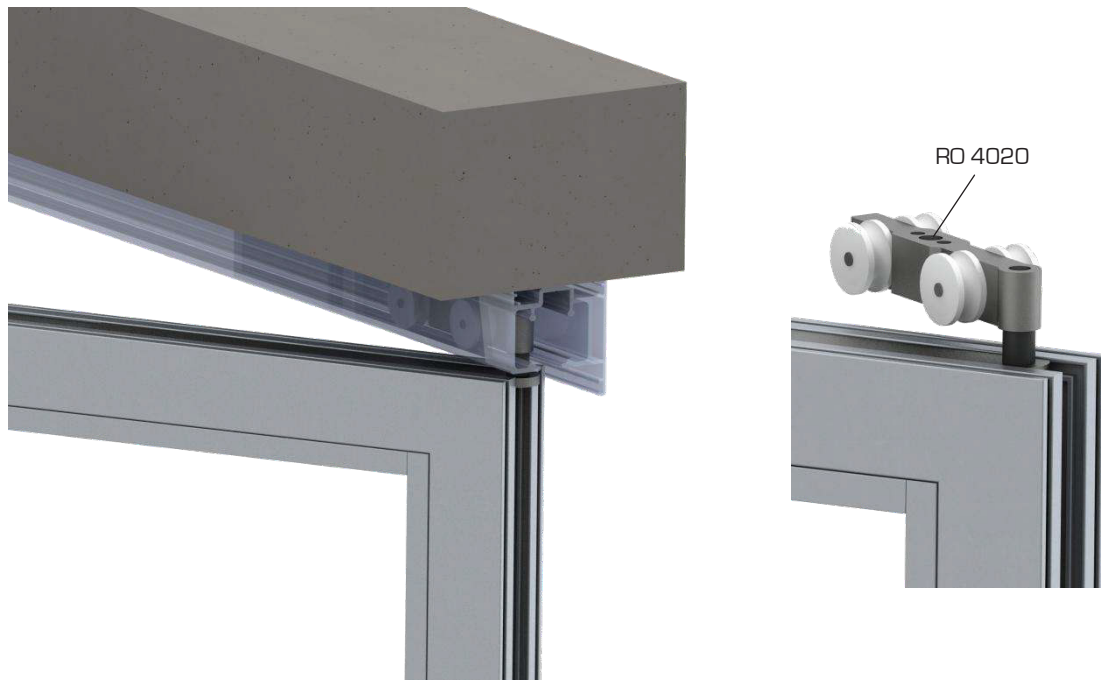

Guía superior encastrada - Rodamiento Superior Hojas Pares

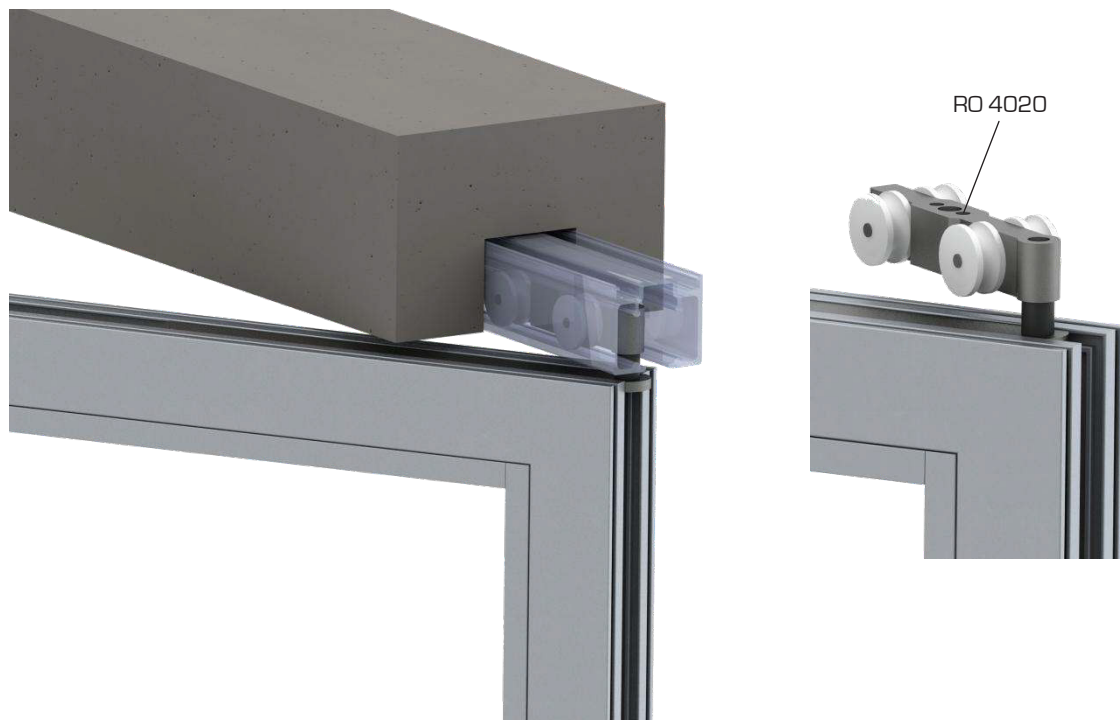

Marco inferior – Rodamiento Inferior Hojas Pares



Guía inferior encastrada – Rodamiento Inferior Hojas Pares



Guía superior con ala – Bisagra Tandem superior



Guía superior encastrada – Bisagra Tandem superior



Marco inferior – Bisagra Tandem inferior



BI 2078



Guía inferior encastrada – Bisagra Tandem inferior



BI 2078





ALUES S.L

Polígono Industrial P29
Calle Tinte nº 4
28400 - Collado Villalba - Madrid
España

Telf: 910641620 / 661 621162
alues@aluessistemas.com